



A1040 MIRA 3D

Ultrasonic low-frequency tomograph

Operation manual

Revision 1.0.6

Acoustic Control Systems - ACS Group
Saarbrücken, Germany 2021

This instruction manual contains essential information on how to use this ACS product safely and effectively. Before using this product, thoroughly review this instruction manual. Use the product as instructed.

1. Cover Page Back	4
2. Cover Page Front	5
3. Important basic information	6
4. Abbreviations	8
5. Lables, position and content	9
6. Scope of Delivery	11
7. Main Components	13
8. Keys and system LEDs	17
9. Rechagreable Battery of the Main Device	20
10. Rechargeable Battery of the Control Unit	23
11. Device usage and Limitations	26
12. Safety	28
13. Maintenance and Repair	30
14. Technical Specification	33
15. Operation	34
16. Trouble shooting	37
17. CE Certificate	41
18. B-Scan	42
18.1 Main parameters	42
18.2 Display parameters	43
18.3 File manager	45
19. MAP	47
19.1 Main parameters	47
19.2 Display parameters	48
19.3 File manager	48
19.4 MAP manager	48
20. C-Det	50

21. A-Scan	52
22. Setup	55
22.1 Instrument configuration	57
22.2 Automatic transducer testing	59
23. Getting started	63
23.1 App installation	63
23.2 App activation	64
23.3 Preparation for work	66
23.4 Update	67
Index	0

1 Cover Page Back



Service Address: ACS-Solutions GmbH
Science Park 2
66123 Saarbrücken
Germany
Phone: +49 (0) 681 9659 2270
Fax: 49 (0) 681 9659 2280
E-Mail: info@acs-international.com
Web: acs-international.com

2 Cover Page Front

A1040 Mira 3D
ULTRASONIC LOW-FREQUENCY TOMOGRAPH
User Manual

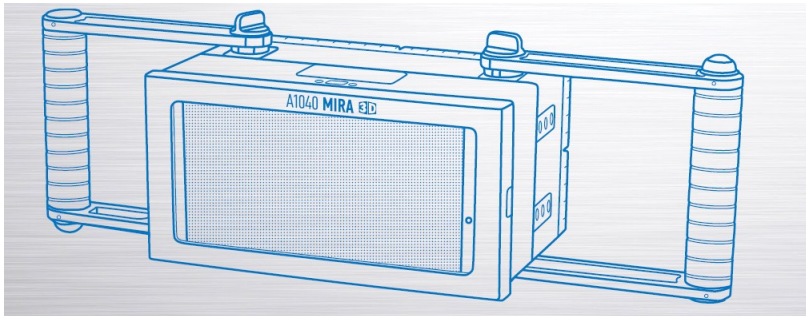

This manual contains important information about the correct and safe use of the device.

Read this manual carefully before using the device for the first time and use the device only in the intended manner.

Always keep this manual in the vicinity of the device.

Revision: 1

Issued: November, 18 th 2020

⚠ CAUTION

Make sure the manual on hand corresponds with the currently installed firmware and control software release on your system.

Check the firmware and control software release that is currently installed on your system (for further information see chapter "[Setup](#)")^[55]

With every firmware and control software update the functionality of the device will change. It is possible that formerly described functions are not available any more, new functions are added or pictograms and/or procedures change. These changes will be documented in the latest, online available manual.

Check [page](#)^[67] for available manuals and software updates.

3 Important basic information

Read this manual carefully before using the device to ensure safe and proper use.

Intended use:

The A1040 MIRA3D device is intended for the ultrasonic inspection of constructions made of concrete, reinforced concrete and stone with one-sided access. The design is for manual operation. For positioning purposes, the device is equipped with 4 positioning Laser-LEDs class 2M.

⚠ WARNING

Never Use the device for any other purposes than stated above. Never use the device on humans or animals. Never look into the Lasers. For further Safety instructions see chapter Safety

The A1040 MIRA3D device must be connected via hotspot to a Control Unit. Only use Control Units approved by ACS for this purposes.

⚠ CAUTION

A1040 Mira 3D is normally equipped with a tablet device as Control Unit that is seated in a specially developed housing. The Control Units provided by ACS are selected to guarantee a save and reliable operation of the all over system. Please do not try to open the provided Housing for the control unit. If the control Unit is damaged or malfunctioning, please contact your ACS support.

⚠ WARNING

Do not try to control the A1040 Mira 3D with other mobile devices that are not specified and provided by ACS, even if the connectivity and capability of executing the control software seems given. This may result in unexpected behavior, personal injury, and / or equipment damage including impairment of safety. ACS is not liable for any damage or loss (whether contractually or unauthorized, including negligence) caused by not following this warning.

This A1040 Mira 3D is CE-certified according to 2014/30/EU (EMC).

Liquid ingress protection and solid particle protection of the casing is in conformity with level IP53 (standard EN 60529), so the equipment is splash proof and protected against dust.

Despite the IP classification, it is possible that the device will be damaged in certain situations. Follow the instructions below to maintain water resistance and dust protection.

- Never immerse the equipment into water.
- After contact with clear water, wipe it thoroughly with a clean soft cloth.
- Contact of the device with liquids other than water may adversely affect the performance and appearance of the device.
- Dropping the device may affect the device protection.
- The device should never be opened by untrained personnel.

Safety symbols used in this Manual:
Symbol

Description



Indicates a potential threat. Failure to avoid it can result in death or serious injury. Indicates a potential threat. Failure to avoid it may result in minor injury.

Indicates a potentially harmful situation. If it is not avoided, the device or something in its vicinity may be damaged.

4 Abbreviations

Geben Sie hier den Text ein.

5 Lables, position and content

Labels are safety related and must be present at all time when the device is in use. Labels are positioned according the Figures ?? below.

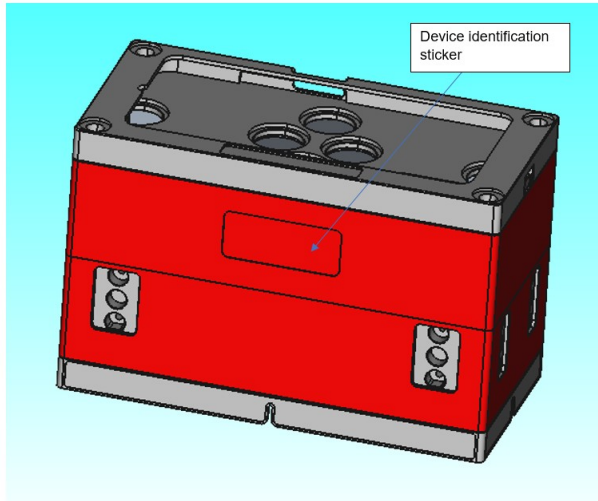

Figure 1: Position device identification Sticker

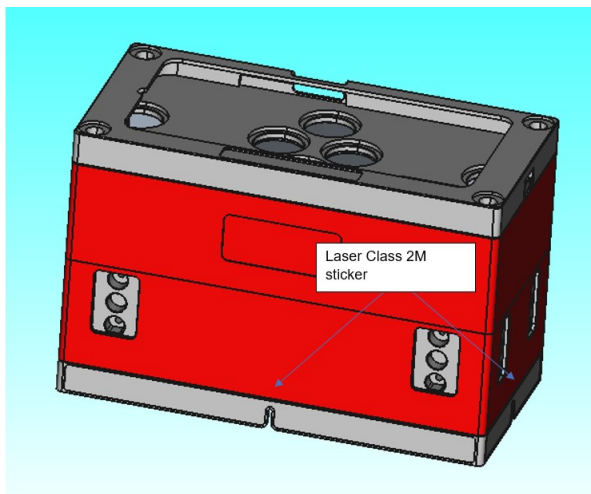

Figure 2: Position Laser class 2M Sticker

Description

device identification Sticker

Content



Device Name: A1040 MIRA 3D

Manufacturer: Acoustic Control Systems-ACS Group

Manufacturer Homepage Address: ACS-Interantiona.com

Country of origin: Made in Germany

CE: Conformity declaration for applicable European Directives

FCC: Conformity declaration for requirements of the Federal Communications Commission (FCC) - relevant for delivery, sales and import to USA.



Sign or "Read manual first"



WEEE symbol that the product contains batteries. These must be collected and disposed of separately according the regional laws.

S/N: Serial number of the Device beginning with 120 followed by 5 digits.

Laser class 2 M



Warning sign placed on the exiting points of all 4 Laser-Diodes. Please see chapter "Safety" for further Detail

6 Scope of Delivery

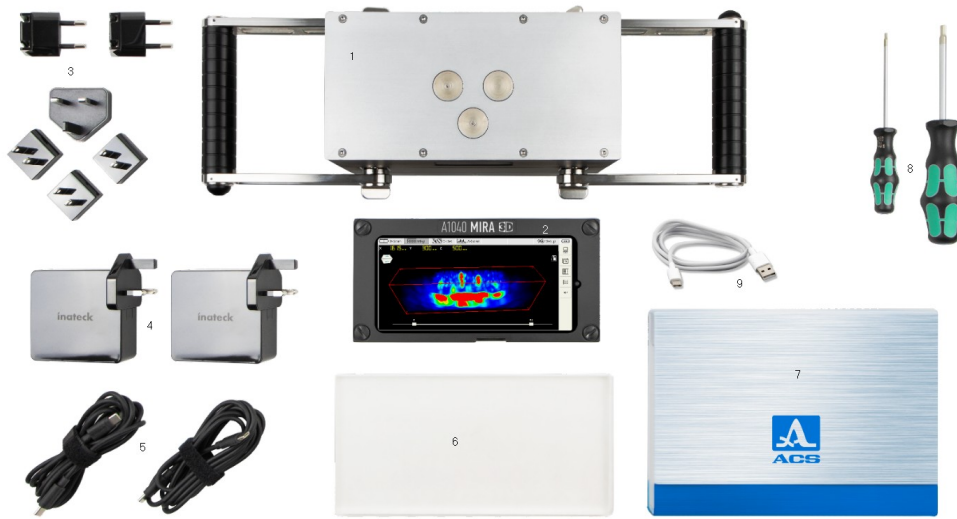

Number	Part description
1	A1040 Mira 3D device
2	Mobile control device
3	Electric socket adapters
4*	Charging devices for A1040 Mira 3D and mobile control device
5	Cables for charger
6	Transducer test plate
7	Documentation box containing the user manual, the warranty certificate and the meteorology certificate.
8	Foam inlay
9	Cable for charging of mobile control device

10

Transportation box

* A1040 MIRA 3D 4x8 configuration is delivered with only one charging device.

7 Main Components

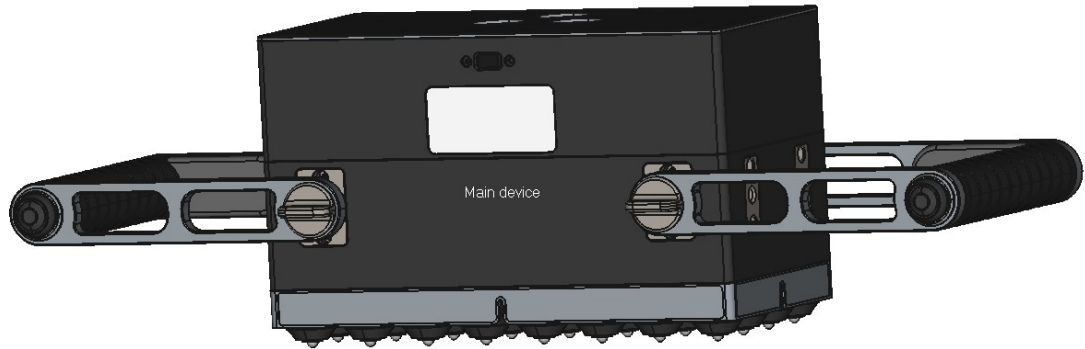

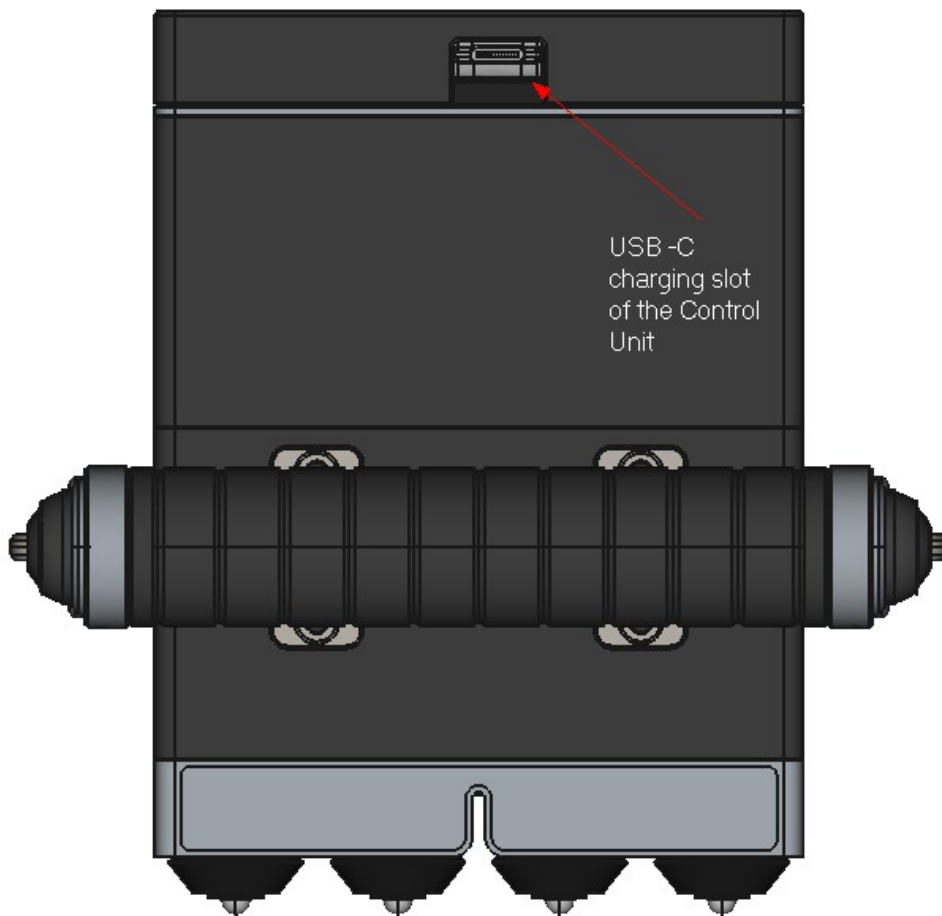
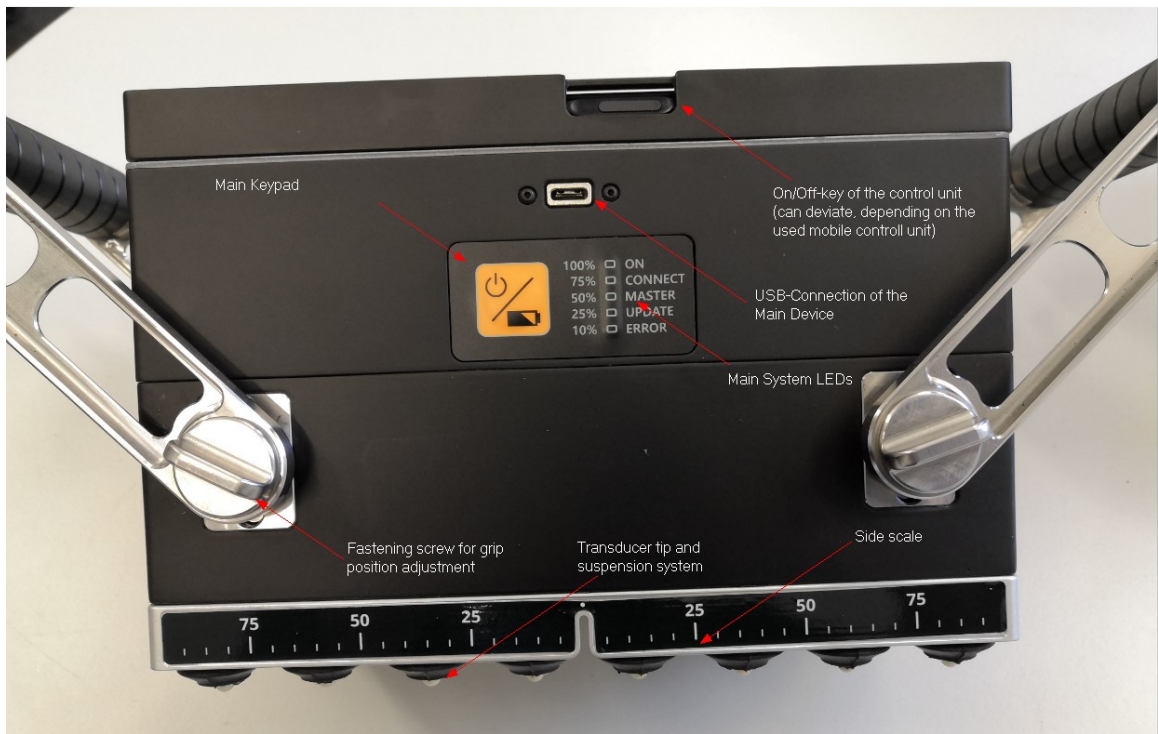

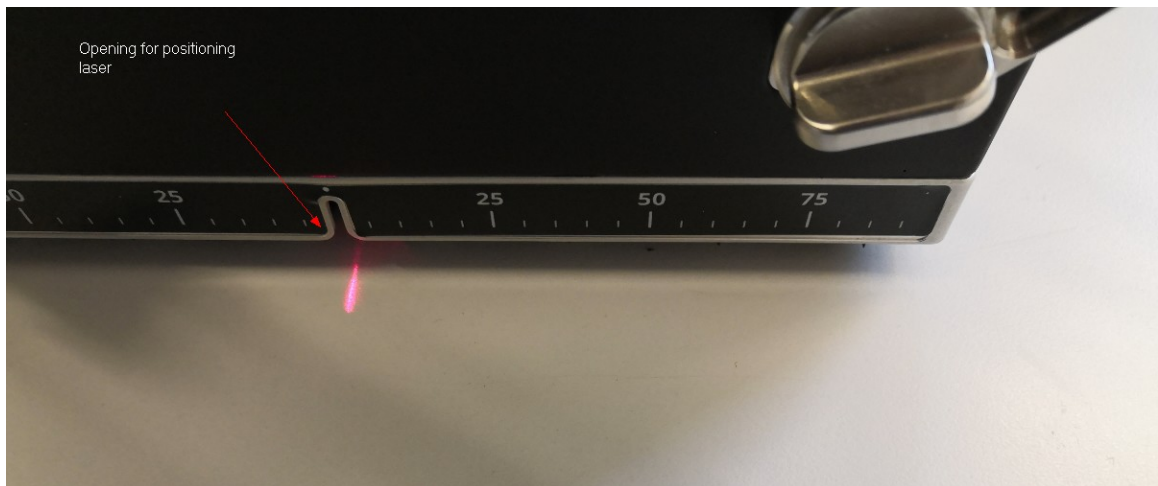
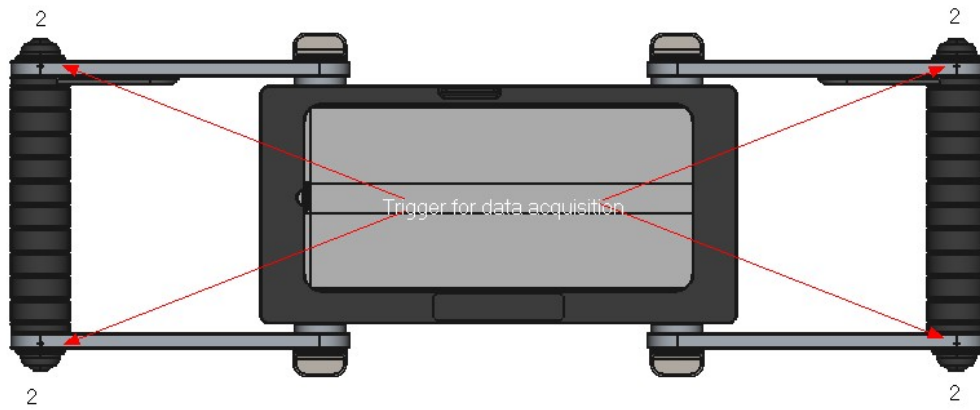

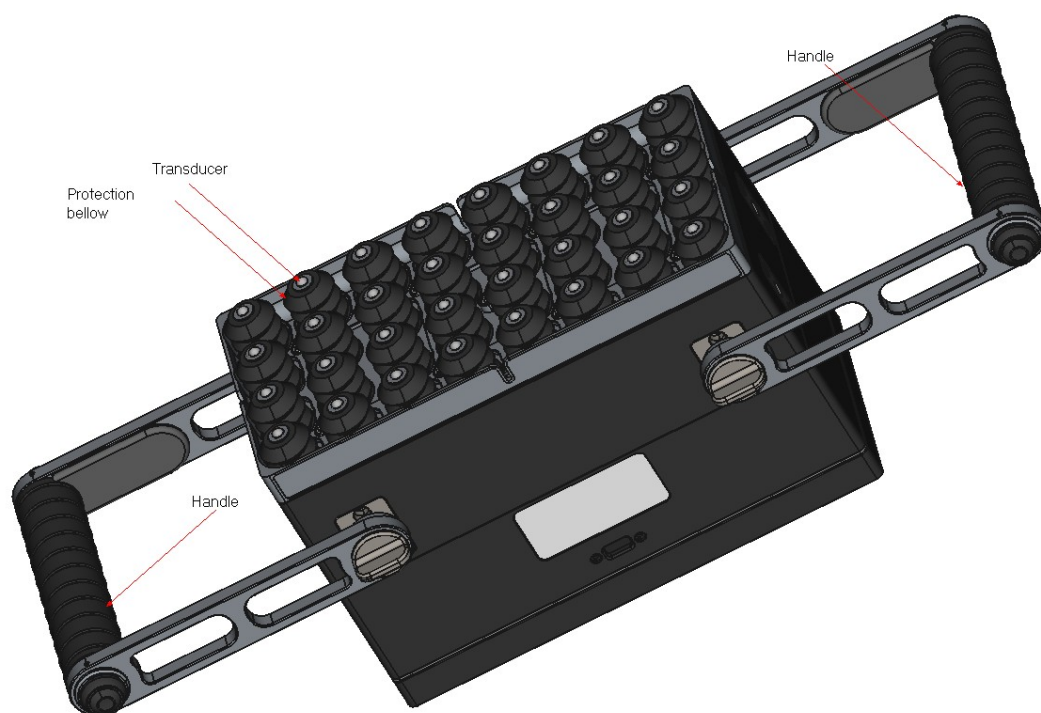

8 Keys and system LEDs

The A1040 Mira 3D Has two key -Types

Type One is the key for the operational preparation of the system and to run status checks. This Key is found on the Main Keypad



Figure 3: Keypad position

The Keypad has three basic functionalities. Switching the device on/off and start the battery charging status. Detailed Information in given in the table below.

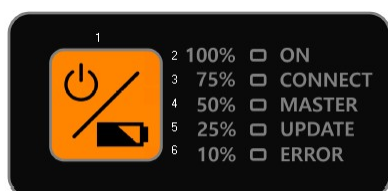
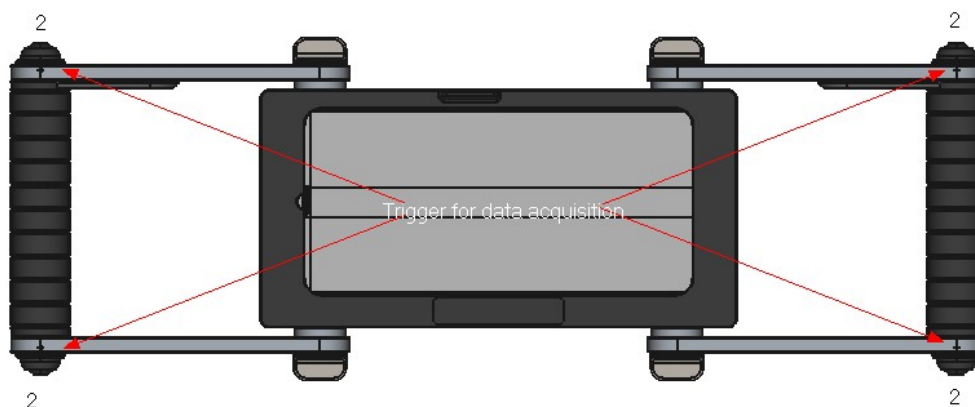

Figure 4: Keypad with LEDs

Key name	Functions
Power Key [1]	Press and hold the POWER Key for 3 seconds to activate the device
Power Key [1]	Press and release the POWER Key for the checking the battery status
Power Key [1]	Press and hold the POWER Key for 3 seconds to deactivate the device
Power Key [1]	Update procedure initiation (see chapter system update)

Type two is are the four trigger keys for the start of the acquisition during the system operation.



Key name	Functions
Trigger Key [2]	Data acquisition
Trigger Key [2]	Update initiation function when using WIFI as access point

The system LEDs have two basic functionalities, displaying the procedure mode and the charging status.

Normal operation mode

LED Name	Functions/Meaning
ON [2]	Not lit when device is turned off Flashing green during hardware initialization and booting Constant green glow when the device is ready for operation
CONNECT [3]	Not lit when device is turned off Flashing green with 1 Hz frequency until a connection is established with the access point of the control device. Flashing green with 2 Hz frequency until the connection with the control program is established. Constant green glow when the Main Device is connected to the control program and ready for operation
MASTER [4]	Not lit: Option 1: The main device is not connected to the control program. Option 2: The main device is acting as slave in combination 4x16 or 8x8 with another device.

Constant **orange** glow when the device is connected as Master to the control program.

UPDATE [5] Not lit when device is in normal operation mode.

Constant **orange** glow when the Main Device is connected to a PC and ready for receiving the update files. See chapter Update at [page 67](#)

Flashing **orange** with 2 Hz frequency during the data transfer process.

Error [6] This LED has no functionality at the moment.

Checking the battery status mode. The LEDs are glowing constantly for a few seconds according the charging status and then switch off. The main device will stay switched off.

100 % [2] **green** 100 % battery charging

75% [3] **green** 75 % battery charging

50% [4] **orange** 50 % battery charging

25% [5] **orange** 25 % battery charging

10% [6] **red** 10 % battery charging *

* at 10 % battery charging. the device should be recharged.

9 Rechargeable Battery of the Main Device

⚠ WARNING

The rechargeable batteries of the Main Device shall not to be replaced by the operator, only by full trained personnel that has been authorized by ACS. For safety reasons, do not attempt to remove or replace the battery.

Incorrect removal or replacement of the battery may result in damage to the battery and the device, personal injury, and / or equipment damage including impairment of safety.

ACS is not liable for any damage or loss (whether contractually or unauthorized, including negligence) caused by not following this warning.

NOTICE

Before first use, the rechargeable batteries must completely be charged.

If the instrument is not used for a period longer than three month, check charging status by press ON key short. When the charge has dropped to 25 %, recharge the device.

Make sure that the accumulator is completely charged once in two months, to prevent total discharge.

In that case of total discharge, the rechargeable batteries may be destroyed and must be replaced.

⚠ WARNING

Use only ACS - approved chargers and cables. Unauthorized chargers or cables may cause the batteries to explode or damage the device.

ACS is not liable for any damage or loss (whether contractually or unauthorized, including negligence) caused by not following this warning.

⚠ WARNING

Incorrect connection of the charger may cause serious damage to the device. Damage caused by improper use is not covered by the warranty.

Charging of the rechargeable battery

1. Connect one end of the USB-C cable to the USB-C power supply, and the other end to the USB-Connection of the Main Device



2. Connect the USB power supply to the mains socket.
3. When the charging process begins, the LED corresponding with the charging level will start to blink and glow constantly. When the status is reached the LED glows constantly and the LED for the next level will start to blink. When the battery is charged 100 %, the 100 % LED is glowing constantly and the charging process is switching to trickle charge.

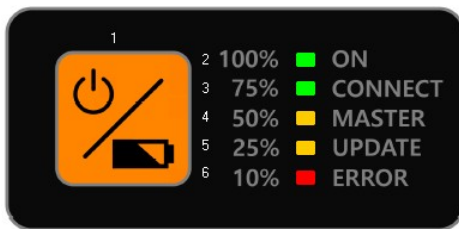

4. Separate the charging unit from the device, as the rechargeable battery has completely been charged.
5. First disconnect the charger from the device and then from the mains socket.

NOTICE

Tips and precautions for charging the battery

- In normal mode the device switches OFF as soon as the level drops beyond a certain safety limit. It is recommended not to restart the device before the charging procedure is complete to avoid damage.
- When the battery is discharged, the device will not turn on immediately after it has been connected to the charger. Charge the battery for a few minutes before turning the device back on.
- If the device is not charged through the USB power supply, but for example via a computer, this may result in a reduced charging speed due to a limited electrical power supply
- You cannot use the device while it is being charged.

- A moderate increase of temperature during charging procedure is not critical. In the case of a drastic temperature rise on the other hand, the charging unit must be removed at once.
- The charger does not have an on / off switch. So, you need to disconnect the charger from the power socket when not in use to prevent wasting energy.
- It is advisable to install the charging unit close to the mains connection and to keep the surroundings free, so that easy access is possible anytime.

10 Rechargeable Battery of the Control Unit

Rechargeable Battery of the Control Unit

CAUTION

A1040 Mira 3D is normally equipped with a tablet device as Control Unit that is seated in a specially developed housing. The Control Units provided by ACS are selected to guarantee a save and reliable operation of the all over system. The housing provides an opening for charging the control unit via the USB-C.

Please do not try to open the provided housing for the control unit. If the control Unit is damaged or malfunctioning, please contact your ACS support.

WARNING

Do not try to control the A1040 Mira 3D with other mobile devices that are not specified and provided by ACS, even if the connectivity and capability of executing the control software is given. This may result in unexpected behavior, personal injury, and / or equipment damage including impairment of safety. ACS is not liable for any damage or loss (whether contractually or unauthorized, including negligence) caused by not following this warning.

WARNING

Use only ACS - approved chargers and cables. Unauthorized chargers or cables may cause the batteries to explode or damage the device.

ACS is not liable for any damage or loss (whether contractually or unauthorized, including negligence) caused by not following this warning.

WARNING

Incorrect connection of the charger may cause serious damage to the device. Damage caused by improper use is not covered by the warranty.

Charging of the Control Unit

1. Connect one end of the USB-C cable to the USB-C power supply, and the other end to the USB-Connection of the Control Unit

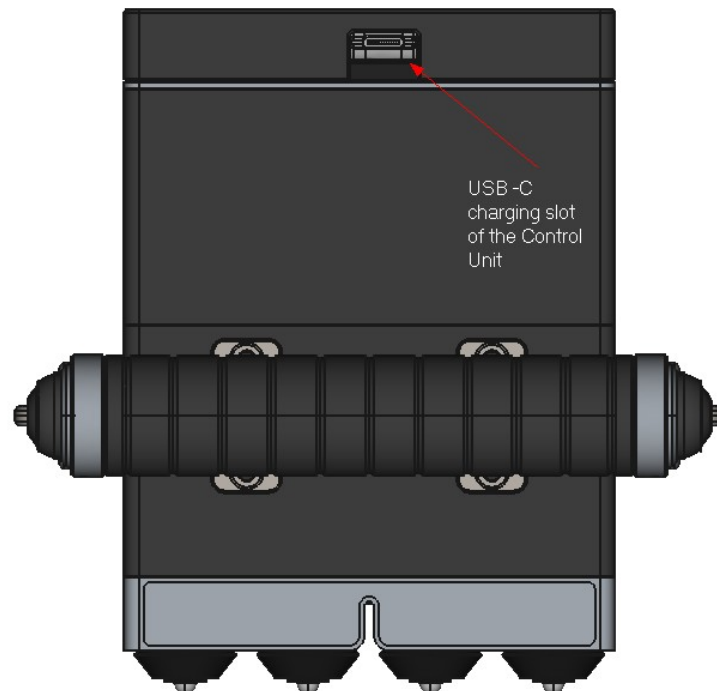

2. Connect the USB power supply to the mains socket.
3. When the charging process begins, the display of the Control Unit states, that the device is charging. When the device is fully charged, the percentage value next to the battery symbol shows 100 %. When the battery is charged 100 %, the charging process is switching to trickle charge.
4. Separate the charging unit from the device, as the rechargeable battery has completely been charged.
5. First disconnect the charger from the device and then from the mains socket.

**WARNING**

Charge mobile control only with dedicated cable. For more information refer [page 11](#).

NOTICE

Tips and precautions for charging the battery

- In normal mode the device switches OFF as soon as the level drops beyond a certain safety limit. It is recommended not to restart the device before the charging procedure is complete to avoid damage.

-
- When the battery is discharged, the device will not turn on immediately after it has been connected to the charger. Charge the battery for a few minutes before turning the device back on.
 - If the device is not charged through the USB power supply, but for example via a computer, this may result in a reduced charging speed due to a limited electrical power supply
 - You cannot use the device while it is being charged.
 - A moderate increase of temperature during charging procedure is not critical. In the case of a drastic temperature rise on the other hand, the charging unit must be removed at once.
 - The charger does not have an on / off switch. So, you need to disconnect the charger from the power socket when not in use to prevent wasting energy.
 - It is advisable to install the charging unit close to the mains connection and to keep the surroundings free, so that easy access is possible anytime.

11 Device usage and Limitations

⚠ WARNING

This section contains safety-relevant information and defines minimum requirements for user groups. Use of the device outside the intended use and by unintended user groups may result in damage.

Intended use

The A1040 MIRA3D device is intended for the ultrasonic inspection of constructions made of concrete, reinforced concrete and stone with one-sided access. The design is for manual operation.

⚠ WARNING

The A1040 shall only be used in controlled areas with no explosive atmosphere.

User groups

Group	Minimum Age	Qualification	Task
Qualified Operator	18 years	Trained in handling of measurement equipment, trained in work safety for the corresponding area	Ultrasonic inspection of constructions made of concrete, reinforced concrete and stone with one-sided access
Apprentices/Trainees/ Students:	16 years	Trained in handling of measurement equipment, trained in work safety for the corresponding area	Ultrasonic inspection of constructions made of concrete, reinforced concrete and stone with one-sided access under supervision.
Public (e.g. visitors)		No user group. The handling of the measuring device is prohibited for these persons.	
Vulnerable persons (e.g. pregnant women)		No user group. The handling of the measuring device is prohibited for these persons.	

Ambient limits

- Temperature Range:
 - Storage: From -20 °C to +60 °C
 - Operation: From -10°C to +50°C
- Relative humidity: 95%

- Contamination: Despite the provided protection according to IP 53 (dust, splash water) always try to minimize the contact of the device with particles and fluids. After use, the device must be cleaned and stored in the transport box provided for this purpose.

Reasonably foreseeable misuse

⚠ CAUTION The device may only be operated by trained personnel. Nevertheless, misuse is not excluded if care is not taken. For troubleshooting, see "Troubleshooting"

Problem cause	Consequence
Incorrect use of the test block	Incorrect measurement
Skewed or improper placement of the device on the testing surface	Incorrect measurement
Insufficient grip of the device, unsafe testing positions, dropping the device	Damage of casing, rechargeable battery, display, electronics. Loss of IP protection.
Insufficient attachment of the handle arm/ open fastening screws for grip adjustment	Dropping of the device and injury by uncontrolled movement of the device.

12 Safety

⚠ WARNING

The general safety instructions listed in this section are relate to the use of the device on workshops and constructions sites under controlled conditions.

These general safety instructions are no replacement for a risk assessment of the workplace according to BetrSichV §3, GefStoffV §6 and ArbSchG §5 and applicable additional national and international requirements by a health and safety officer or a specialist for occupational safety of the employer.

General safety instructions:

- The equipment should not be handed over to persons not aware of inherent risks of the device use or not knowing the content of this manual.
- Be sure to stand securely when measuring with the device.
- Keep a good posture during the handling of the device and avoid movements that will overloading your joints, ligaments and muscles your .
- Pay attention to your environment and potential hazards during the measurement.
- Always mechanically secure the device from falling when used in elevated positions or areas. harm when falling out of high..

⚠ WARNING

The Device contains four Class 2M laser for positioning purposes. The Laser are located at the bottom of the device.

Specific safety instructions:

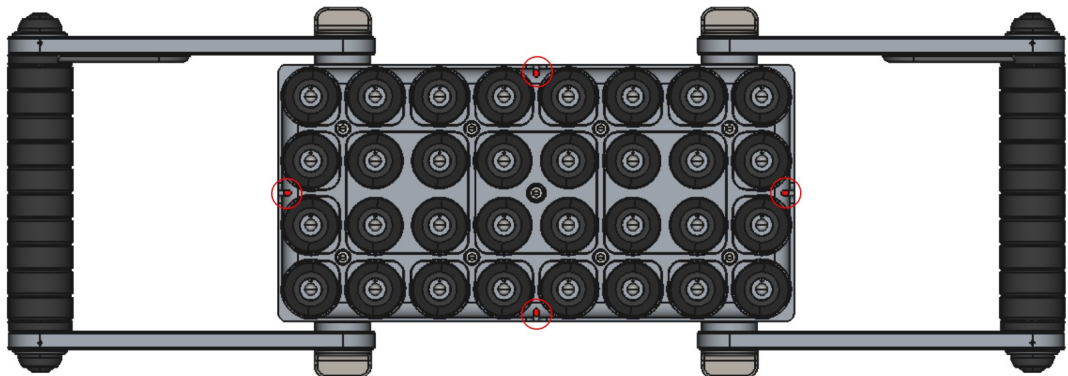

All laser outlets are marked with the following symbol

Protective measures:

-
- Work with laser systems may only be carried out by trained and qualified persons.
 - Avoid looking directly into the laser beam (direct or reflected beam).
 - If the lasers are not needed, switch the lasers off.
 - If you do not work directly with the laser, keep your distance to the equipment.
 - Laser radiation, may only extend as far as necessary for the task at hand.
 - Do not wear watches and jewelery during the use of the lasers to avoid accidental reflections.
 - The beam cross section must not be reduced.
 - Laser equipment shall be installed or secured in such a way as to avoid any unintentional change in its position and beam direction, including those located in the beam path.
 - A minimization requirement applies both with regard to the spatial size of the laser area and the number of people staying in the laser area.
 - Keep laser under lock to prevent misuse.

13 Maintenance and Repair

NOTICE

For this measuring device, calibration is imperative. It should be included in the measuring equipment monitoring of the enterprise.

⚠ CAUTION

Always keep the A1040 Mira 3D clean and maintained state. Avoid unnecessary force when using the device and always dry and clean the device before storage. For storage use the provided box with the foam inlay. Also clean and dry the insides of the box before the device is stored inside. See chapter Troubleshooting for first steps if you are in need of help or find any malfunctions.

Preventive Maintenance

Parts Concerned	Action
Housing	Check for mechanical damage.
Transducer mechanics	Check for smooth operation, mechanical damage and cleanliness NOTICE Never try to remove the protection bellows . Never try to lubricate the the suspension system.
Transducer tips	Check for mechanical damage and cleanliness
Protection bellows	Check for mechanical damage and cleanliness
Information Sticker	Check for completeness and readability.
USB-C socket	Check for mechanical damage and cleanliness.
Control Unit	Check for mechanical damage and cleanliness.
Transducer test plate	Check for mechanical damage and cleanliness.

Housing	Check for mechanical damage.
Transducer mechanics	Check for smooth operation, mechanical damage and cleanliness NOTICE Never try to remove the protection bellows . Never try to lubricate the suspension system.
Transducer tips	Check for mechanical damage and cleanliness / Clean the transducer tips with a small, soft brush and a little moistened cloth.
Protection bellows	Check for mechanical damage and cleanliness / clean the Protection Bellows with a small, soft brush and a little moistened cloth.
Information Sticker	Check for completeness and readability / Clean with a little moistened cloth / Ask service for replacement of missing or unreadable stickers.
Control Unit	Check for mechanical damage and cleanliness / Clean with a little moistened cloth
Complete A1040 Mira 3D system	Inspection and calibration by ACS or authorized dealer.

Control procedures and test equipment

Correct functionality is inspected by means of the test plate contained in the set. The procedure is detailed at [page](#)⁵⁹.

Documentation of Maintenance

The annual inspections must be documented by factory service or the authorized person for measuring equipment monitoring.

Repair

Repair is reserved to factory service or authorized dealer.

Initial Step for Troubleshooting

In case of device failure switch OFF and ON the device. If the device problem is not solved, consult the chapter troubleshooting.

14 Technical Specification

NOTICE

The technical specification is given in the A1040 Mira 3d warranty certificate, chapter 3 "Main Technical Specifications", that was given to you as part of the delivery set.

NOTICE

The technical specification can be altered by ACS anytime by means of optimizing the device or for safety reasons. Please check the homepage path of [A1040 MIRA 3D](#), for the latest technical specification of the device.

15 Operation

NOTICE

The given operation description of this chapter relates only to achieve a status of operation readiness. All parameters available for setting to meet the develop a testing procedure and to perform tests are described in the chapters x,y,z,

Set up of the Grip position

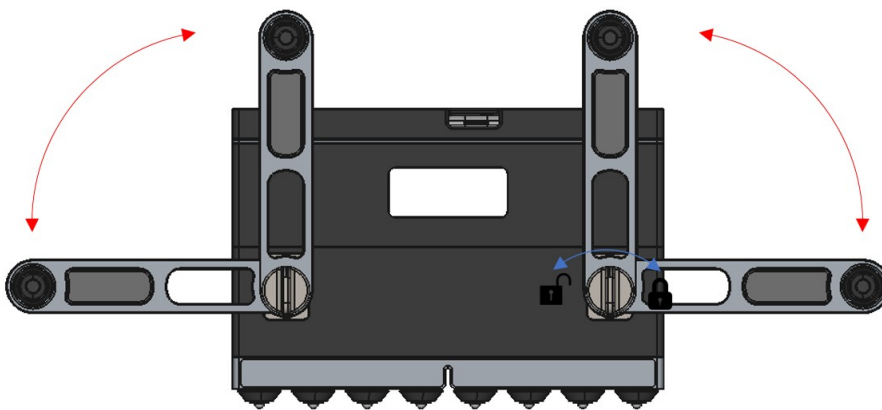

NOTICE

The handle screws are designed to be operated by hand only. For the operation of the screws only little force is needed for secure fastening results. Never use tools on the handle screws !



Unlock the handle fastening screws on both sides of the handle by rotating them counter clockwise.

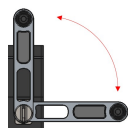

Move the Handle into one of the four possible positions.



Lock the handle fastening screws on both sides of the handle by rotating them clockwise

Repeat the operation on the other handle.

Attachment and detachment of the control device

Place the Control Unit on the Main Unit like shown in the sketch below, gripping it on the corners.

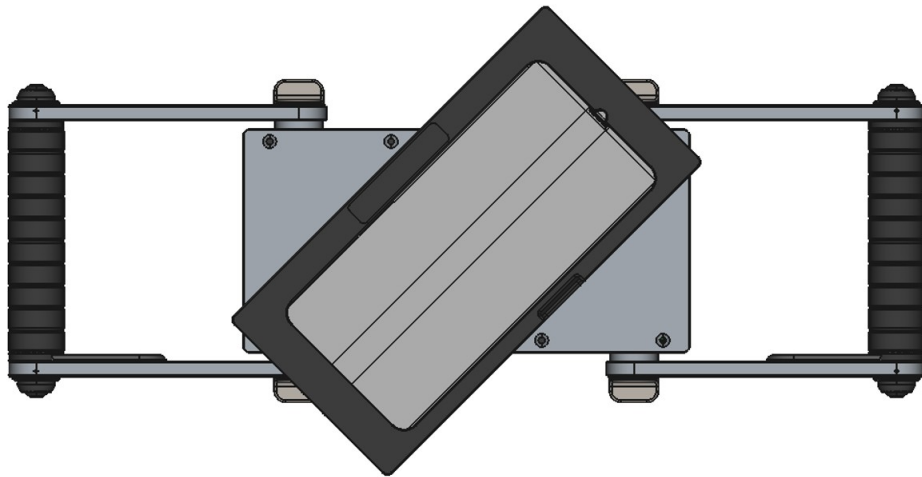

Rotate the Control Unit, gripping it on the corners, clockwise until the magnetic locking system snap into place.

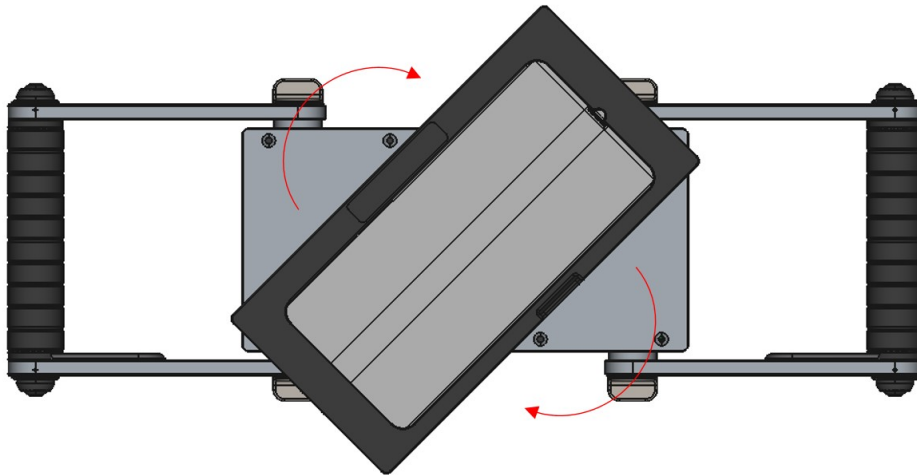

Correctly placed Control unit

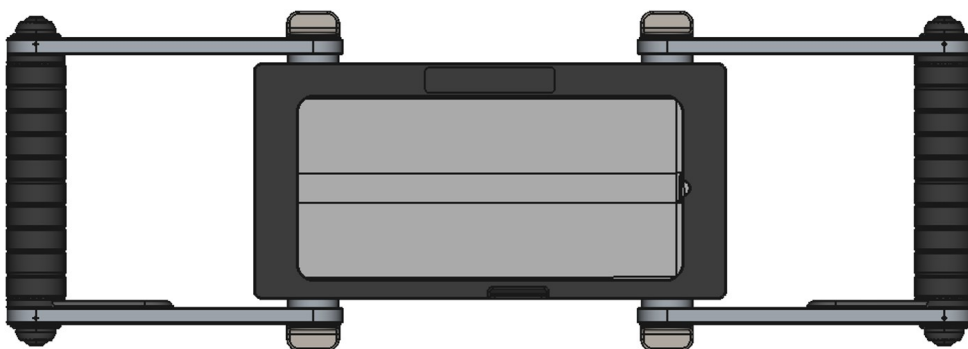

For detachment repeat the procedure backward.

Rotate the Control Unit, gripping it on the corners, until the magnetic locking system snap out of place .

Remove the Control Unit from the Main Unit.

Switching on the A1040 Mira 3D system

NOTICE

Before switching on the A1040 Mira 3D system, check the status of the batteries according the chapters "Rechargeable Battery of the Main Device" and "Rechargeable Battery of the Control Unit"

Press On Key [1] for three seconds to switch the Main device on.

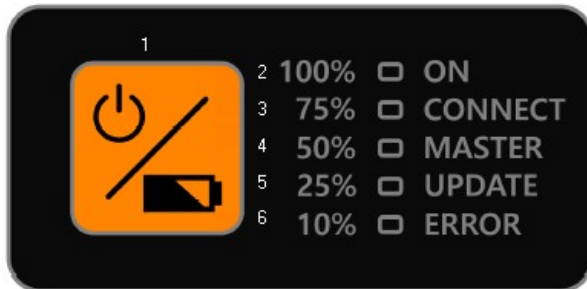

Switch on the Control Unit by pressing the On Key, shown in the figure below



Switching off the A1040 Mira 3D system

Press On Key [1] for three seconds to switch the Main device off.

Switch off the Control Unit by pressing the On Key

16 Trouble shooting

Problem	Possible Reason(s)	Action
<p>Main Device does not switch on.</p> <p>The ON LED is not flashing green after pressing the ON key for three seconds.</p>	<p>Rechargeable Battery not charged</p> <p>The Main Device has a malfunction that can only be determined by trained service personnel</p>	<p>Press the ON Key short to check the Battery charging status. If the status is low (e.g. the red LED that equals 10 % is blinking) charge the batteries.</p> <p>Send the device back for repair in its original box, or hand it over to a designated collection point for recycling.</p>
<p>Main Device does not initialize the hardware and boot the firmware.</p> <p>The ON LED is flashing green after pressing the ON key for three seconds but is not constantly glowing after some time.</p>	<p>The software of the Main Device is malfunctioning or was damaged.</p> <p>The Main Device has a malfunction that can only be determined by trained service personnel</p>	<p>Switch off the Main Device by pressing the ON key for three seconds.</p> <p>Switch on the Main Device by pressing the ON key for three seconds.</p> <p>Try to perform a firmware update according chapter Update⁶⁷.</p> <p>Send the device back for repair in its original box, or hand it over to a designated collection point for recycling.</p>
<p>Main device is not detected by mobile unit.</p>		<p>NOTICE</p> <p>The product must not be disposed of with the domestic waste</p>
<p>Laser does not work or is blurred</p>	<p>Dirt or or a small item is blocking the laser beam outlet.</p>	<p>Switch off the laser LEDs by the control software.</p> <p>Check if the LEDs are off by placing the device on white A4 sheet of paper, or similar. .</p>

The LED is damaged

When the LEDs are off, turn the device to the and clean the laser beam outlet with a small blower ball, soft brush or piece of cloth.

Check the outlet and the lens for cleanliness.

Check the function by placing the device on on white A4 sheet of paper, or similar and switch the laser LEDs on by the control software.

⚠ WARNING

Never look directly in the laser beam and make sure, that the laser beam is never directed to the eyes of any bystander. Also avoid mirroring surfaces like glass, liquids or polished metal objects.

Send the device back for repair in its original box, or hand it over to a designated collection point for recycling.

NOTICE

The product must not be disposed of with the domestic waste

Transducer is stuck / suspension is not working

NOTICE

Never try try to remove the protection bellow .

Never try to lubricate the the suspension system.

Dirt intrusion due to damaged or loosened protection bellow.

Check the protection bellow for damage and if it is disassembled. A well assembled an intact bellow is shown in the sketch below.

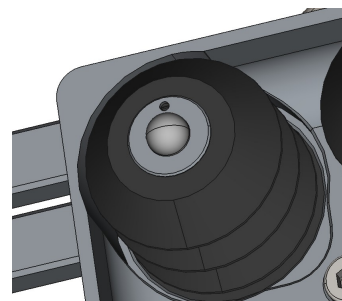

If the bellow is disassembled, carefully try to retract the bellow until the sensor suspension is visible. Try to clean the

suspension with a small brush and a little moistened cloth.

Check if the suspension is working now.

Place the bellow back and make sure the end of the bellow rests now in the designated groove.

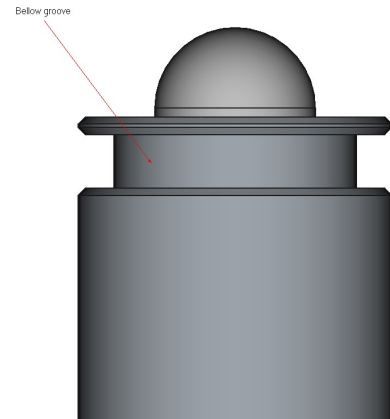

If the bellow is damaged, it must be replaced by a service technician.

Send the device back for repair in its original box, or hand it over to a designated collection point for recycling.

Spring malfunction/damage or damage at the mechanical transducer guiding system.

NOTICE

The product must not be disposed of with the domestic waste

Main device is not detected by the Mobile Unit

Malfunction during the coupling process

Check if the On LED on the Main Device is glowing **green** constantly.

Switch off the Mobile Unit.

Switch on the Mobile Unit

Go to chapter at [page 66](#) and follow the instructions for the device coupling process.

Software malfunction

Check if your Control Software on the Mobile Unit is starting properly.

If the software is not responding properly, reinstall the software on your Mobile Unit.

Plattentest fail

Main Device does not switch off after pressing the ON key for three seconds.

The control software is malfunctioning.

The Main Device has a malfunction that can only be determined by trained service personnel

Disconnect the Mobile Unit from the Main Device.

Disconnect all cables from the Main Device.

Retry switching off by pressing the ON Key for three seconds

Let the Main Device switched on, until the batteries are discharged enough and no LEDs is lit any more.

Send the device back for repair in its original box, or hand it over to a designated collection point for recycling.

NOTICE

The product must not be disposed of with the domestic waste.

17 CE Certificate

**Declaration of Conformity according to EMC Directive 2014/30/EU****The manufacturer / distributor**

ACS-Solutions GMBH, Science Park 2, 66123 Saarbrücken Germany

hereby declares that the following product

Product name: Low-Frequency Ultrasonic Tomograph
Trade name: Ultrasonic measuring device
Model name: A1040 MIRA 3D

complies with the provisions of EMC Directive 2014/30/EU, including any changes in force at the time of the declaration.

The following harmonized standards have been applied:

EN 55011:2016	Industrial, scientific, and medical devices - Radio interference - Limit values and measurement methods
EN 61000-6-2:2015	Electromagnetic Compatibility (EMC) - Part 6-2: Basic Technical Standards - Immunity for Industrial Sectors
EN 61000-4-2:2009	Electromagnetic Compatibility (EMC) - Part 4-2: Test and measurement methods - Testing of immunity against the discharge of static electricity
EN 61000-4-3:2006+ A1:2008+A2:2010:	Electromagnetic Compatibility (EMC) - Part 4-3: Test and measurement methods - Immunity testing against radiofrequency electromagnetic fields

The test results were documented in EMC Test Report 83418_24112020_A1040 MIRA 3D from 30/11/2020 by SGS TÜV.

The following national or international standards (or parts/clauses thereof) and specifications have been applied:

EN 61010-1 Safety requirements for electrical equipment for measurement, control, and laboratory use - Part 1: General requirements

Procedures for carrying out risk analysis

Directive 2014/30/EU, Annex I, point 1 and Annex II Module A

Risk assessment procedures

DIN ISO/TR 14121-2 Safety of machines - Risk assessment - Part 2: Practical guide and process examples, 6.3 Risk graph

Location: Saarbrücken

Date: 11.12.2020

Dr. Andrey Bulavinov (Managing Director)



18 B-Scan

B-Scan serves for fast random measurements along the object. These measurements are considered to be spatially independent. In a short period of time, the operator can optimize measurement parameters taking into consideration different areas of the object. Measurement of the object thickness as well as sound velocity can also be done on the fly. Moreover, examination of suspicious areas, location of reinforcement, etc. is also offered.

18.1 Main parameters

Main parameters tab of B-Scan mode mostly contains parameters which affect ultrasonic characteristics of measured signals. The screen of the main parameters tab and its description are given below.

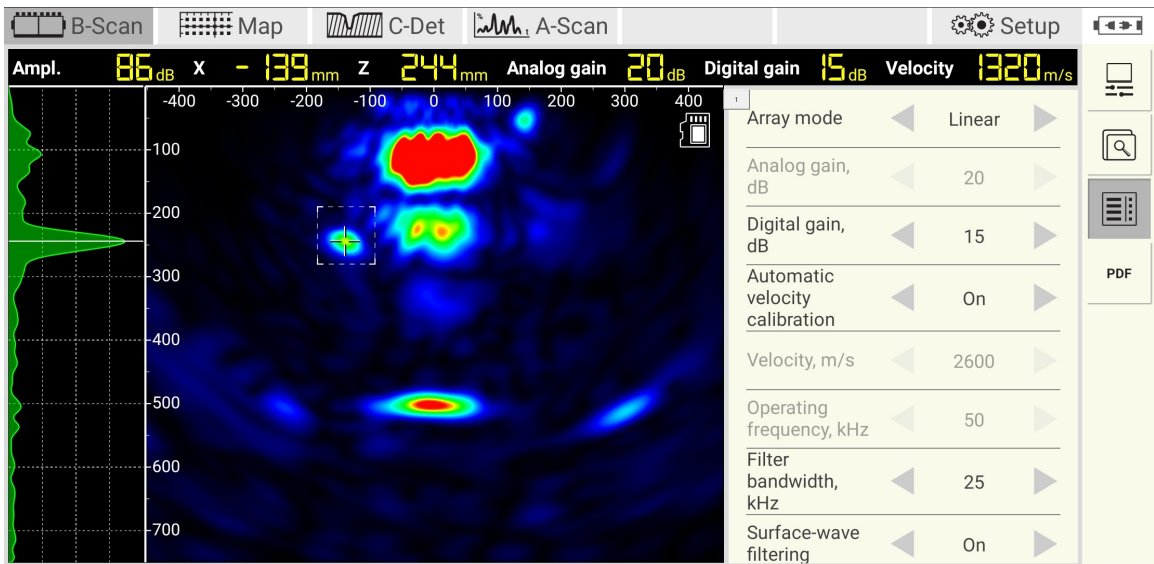

Table 1: Description of controls

Lable	Description
[1]	Panel with list of parameters. Operator can scroll the list of parameters up and down by using touch. Put a finger on the panel, hold it pressed and move it up or down

Table 2: Description of parameters

Parameter	Description
Array mode	Switches between linear or matrix device mode.
Analog gain, dB	This parameter can be used to increase the analog signal amplitude before it is being transformed into a digital signal by A/D-converter. Analog gain is expressed in db. It is preferable to apply the analog gain first since it extends the usage of A/D-converter digital resolution. Decrease analog gain in case of saturated signals.
Digital gain, dB	This parameter can be used to increase the digital signal after it has passed the A/D-conversion. Digital gain is expressed in db. Digital gain does not improve digital resolution rather equally amplifies both signal and noise. The parameter allows to improve contrast of resulting images.
Operation frequency, KHz	Sets frequency of excitation pulse on ultrasonic transducers. Default frequency is 50KHz-
Filter bandwidth, KHz	Digital filter bandwidth with central frequency equal to operation frequency.
Show TGC	Option to show/hide TGC curve on an A-Scan.
TGC, dB/ μ s	Defines slope of analog TGC expressen in dB/ μ s
TGC delay, μ s	Defines zero-delay of TGC curve
Transmitter pulse sequence	Defines number of half-periods for excitation pulse. Value 0.5,1,... stand for 1 half-period, 2 half-period (or one period) etc.

18.2 Display parameters

Display parameters allows user to adjust representation of inspection results in a best suitable way. Main screen of display parameter tab and corresponding description are given below.

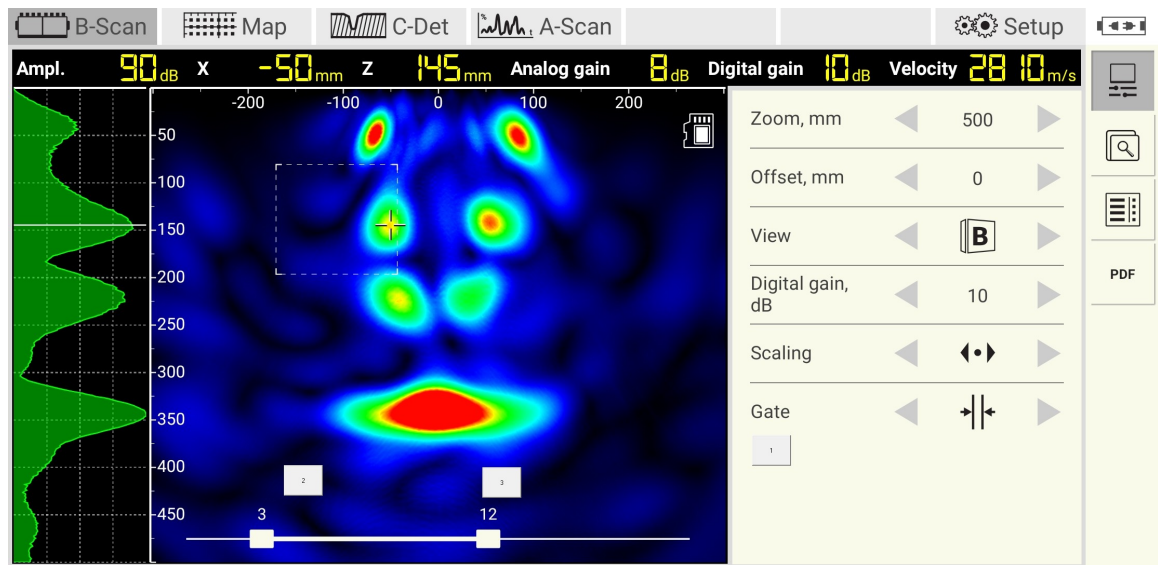









Table 3: Description of controls

Lable	Description
[1]	Tab with listed display parameters
[2]	Start gate control. Defines first cross-section to be projected
[3]	End gate control. Defines last cross-section to be projected.

Table 4: Description of parameters

Lable	Icon	Description
Zoom		Parameter specifies limit of B-Scan inspection depth. Available in liner array and matrix array mode.
Offset		
View		Data are shown as a flat B-Scan (front view) image. In matrix array mode the operator can setup desired projection depth by means of Gate control.
		Data are shown as 3D volume. Aavailable in linear and matrix array mode
		Data are shown as flat C-Scan (top view) image. In matrix array mode operator can setup desired projection depth by using of Gate control.
Scaling		Depth and width relations of B-Scan or C-Scan are proportional. The operation can scroll an image both left and right using touch.
		B-Scan or C-Scan are fitted to screen. Depth and width proportions are not preserved.
Gate		Allows the operator to examine data using cross-sections
		Operator can setup a number of cross-sections which will result into a single image.

18.3 File manager

File manager allows operator to save data, load offline data, rename measurements, delete measurements.

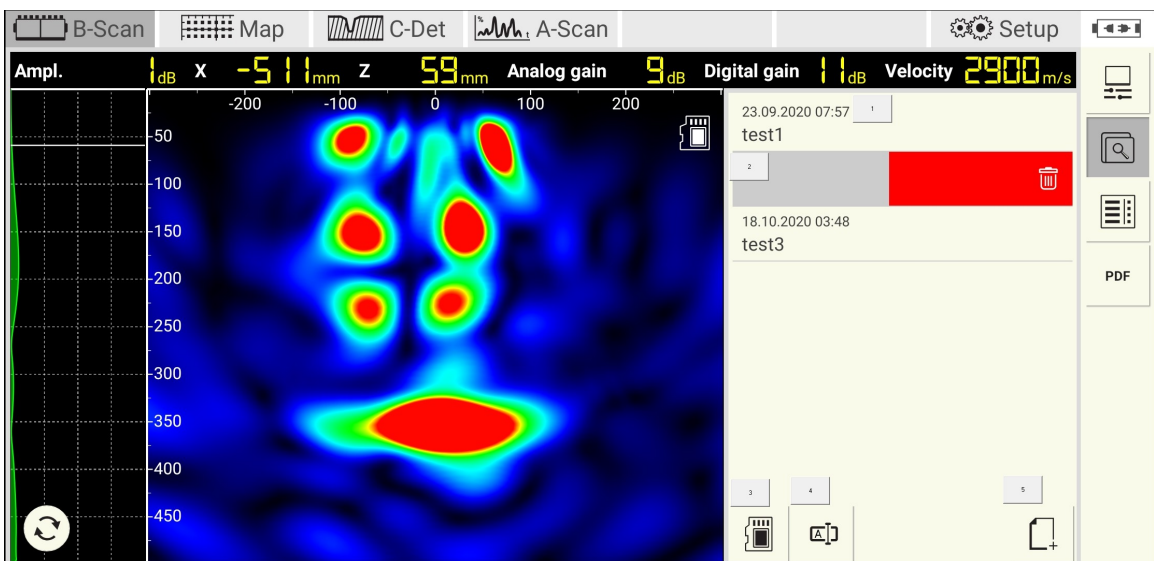

Table 5: Description of controls

Label	Description
[1]	List of saved measurements with name, saving data time. The list can be scrolled up and down by touching with a finger and simultaneous moving up and down. Shot tip on the list causes selection of the desired measurements followed by loading of corresponding data.
[2]	Allows the operator to delete list entry by holding long touch with simultaneous horizontal right to left movement.
[3]	Save as button causes appearing of touch keyboard for entering a measurement name.
[4]	Rename control
[5]	New measurement control

19 MAP

MAP mode allows the operator to carry out areal scanning of inspected objects. The operator is given a great variety of function to setup: area of interest, its dimensions, step size, scanning direction etc. Apart from this setting, the software has a number of integrated visualization features, data representation modes and analysis tools. Operator of can observe results of scanning even in real time while progressing with data collection. Description of functions, parameters and settings is given in the following chapters.



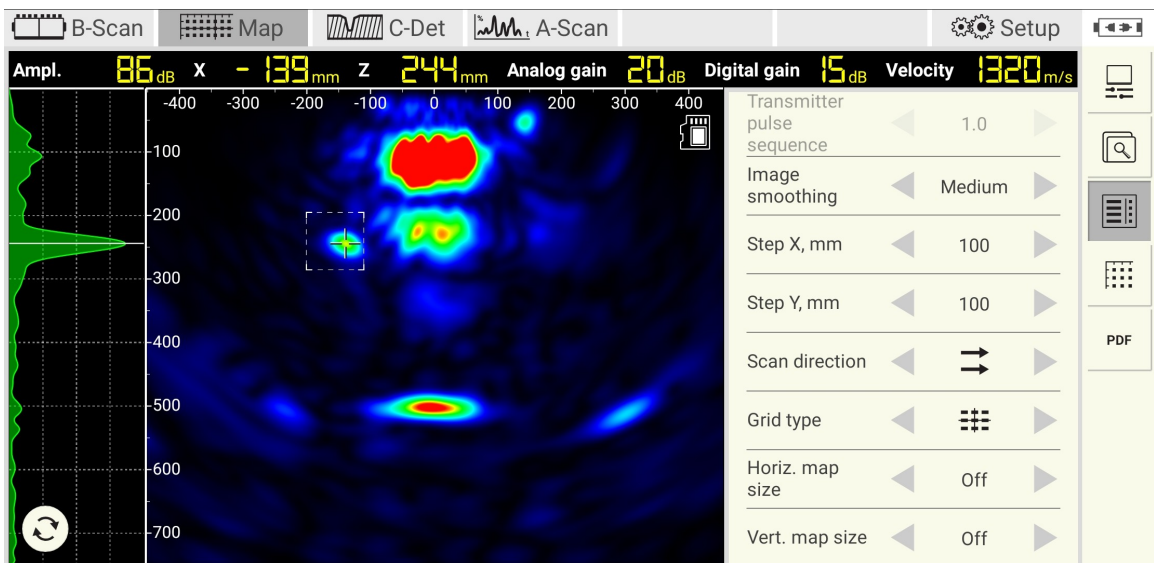

19.1 Main parameters

Main parameters of MAP mode are listed in corresponding tab as it shown below.



In MAP mode in comparison to B-Scan mode the list of main parameters has been extended. For description of standard parameters refer [to](#)⁴². Additional MAP parameters are listed in table below.

Table 6: Description of parameters

Lable	Icon	Description
Step X		Defines distance between measurement positions along X axis
Step Y		Defines distance between measurement positions along Y axis
Scan direction		Defines next measurement position with respect to the current one. Left, right, up and down options are available.
Grid type		Allows operator to load data from the selected measurement position.
		Allows operator to project all data to a single (panorama) image from the selected row. Merging is carrying out in accordance with xy coordinate.
		Allows operator to project all data into a single (panorama) image from the selected column. Projection is carrying out in accordance with XY coordinate.
		Allows operator to project all data from the selected area into a single (panorama) image.
Horiz. map size		Defines the limit of measurement positions along X axis . After reaching the last position operator will be offered to start a new horizontal line. Operator may switch off the limits.
Vert.map size		Defines the limit of measurement positions Y axis. Behaves similar to Horiz. map size

19.2 Display parameters

Display parameters in MAP mode are the same as in B-Scan mode. Please, refer to the list of display parameters [here](#)^[43].

19.3 File manager

File manager in MAP mode has similar functionality as the manager in B-Scan mode. Please, refer to file manager description [here](#)^[45]

19.4 MAP manager

MAP manager parameters are listed in the corresponding tab as is shown below.

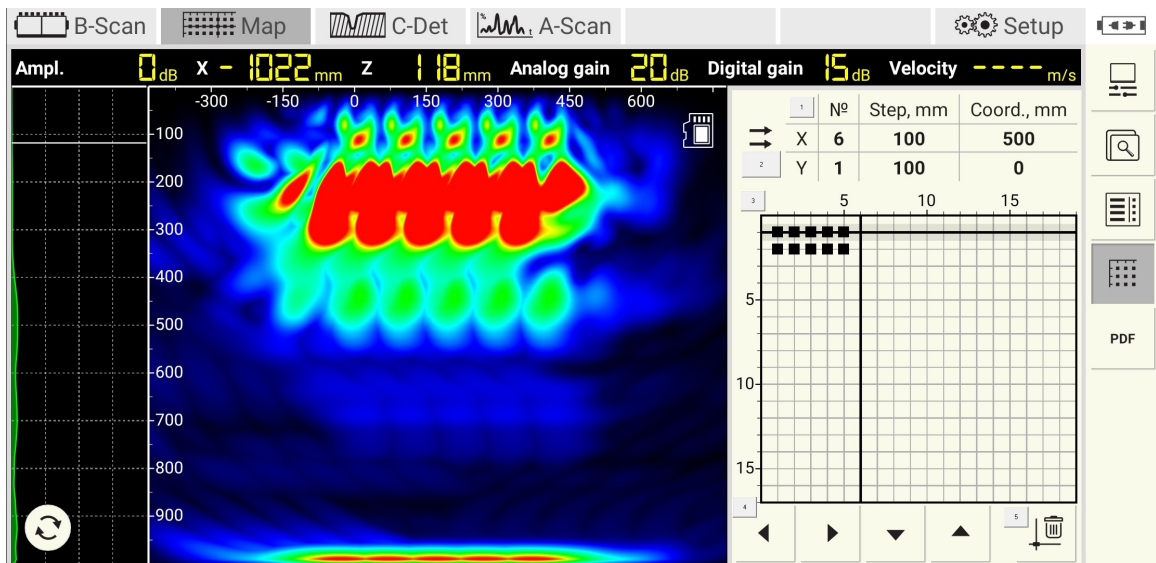

Table 7: Description of parameters

Label	Description
[1]	Table presents main parameters of the map. First column (Number) shows cursor/device coordinates in XY plane. Second column (Step) shows step size along X and Y axis in. Third column (Coord.) shows actual position of cursor/device in XY plane.
[2]	Indicator depicts scanning direction. There are following options: left, right up and down. Operator can setup scanning direction over main parameter tab.
[3]	<p>Map grid indicates position where data were taken. Following actions are available on the map grid:</p> <ul style="list-style-type: none"> • pan grid area. This option can be activated by double click on any free grid space. Hold touch and move a finger to pan • move cursor by touch or arrow control [4] • delete data set at selected position by pressing on trash bin button [5]

20 C-Det

C-Det (crack detection) mode allows the operator to evaluate open crack depth. Notice that the evaluation algorithm requires the crack length on the surface to be larger than 100 millimeters to provide realistic results. C-Det works only in `matrix array` mode. Switch off `automatic velocity calibration` since the surface wave does not propagate through the open crack. For main parameters, display parameters, and file manager operation, please, refer to the corresponding chapters of [B-Scan](#).⁴²

Measurements

Perform the measurements as follows:

- Keep attention that the crack is located between the fourth and fifth row of transducers, **Figure 4**
- Switch off `automatic velocity calibration`
- Set desired `velocity`. If velocity is not known try to estimate it on crack-free surface or using back-wall.

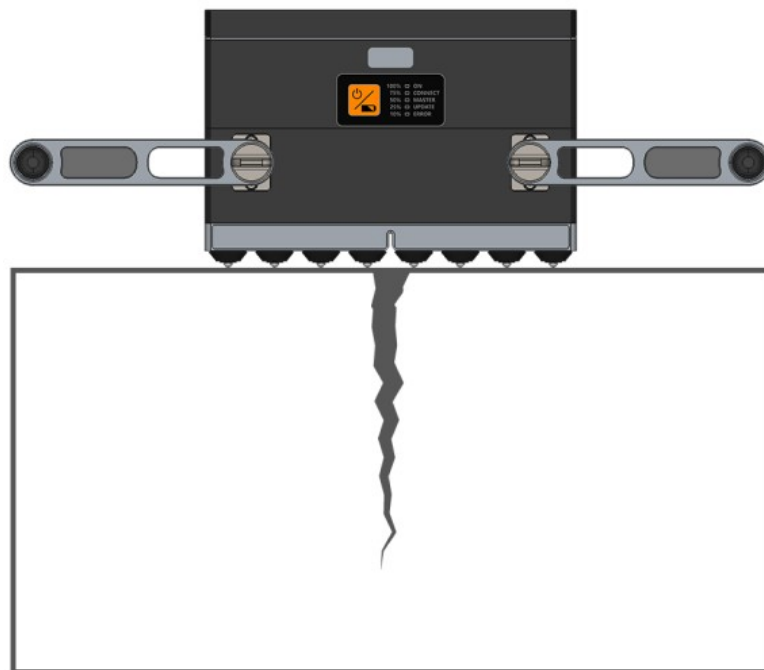

Figure 5: Crack-depth estimation

Evaluation

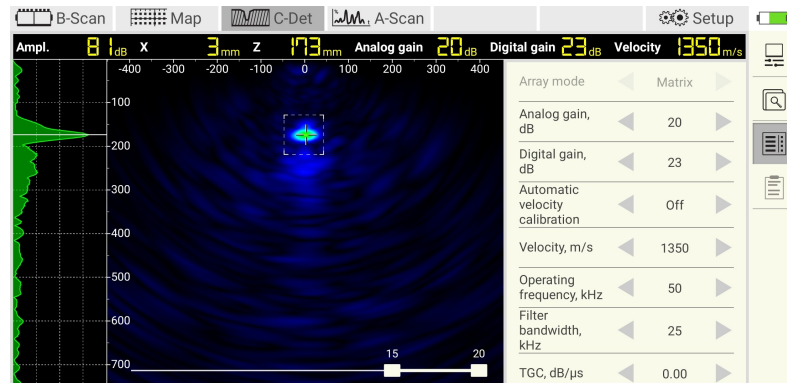

Figure 6: Crack-depth evaluation

- Try to locate the area of interest using the cursor (Figure 6)
- Estimate x and z location of the crack-pitch

21 A-Scan

A-Scan mode allows to carry the following operations: observe waveform measured by specific transducers; fine tuning of analog and digital gain, analysis of the signal with respect to noise, carry out visual check of receivers and transmitters; tuning of TGC in far field; single waveform time estimation using gates etc. Main screen of A-Scan mode is given below.

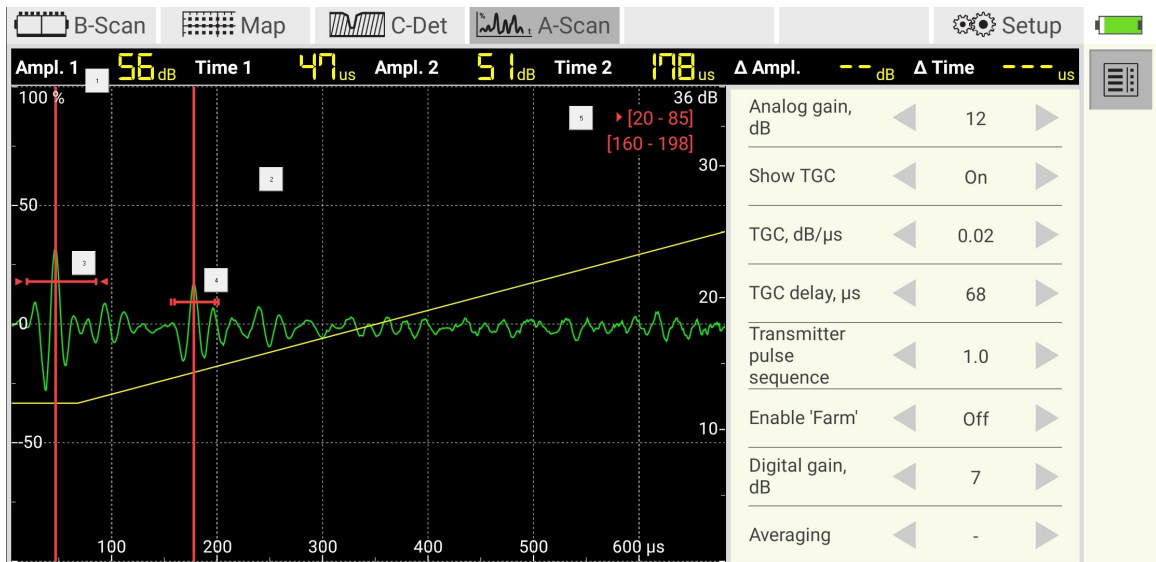











Table 8: Description of visual elements

Label	Icon	Description
[1]	-	Panel shows following parameters: first/second gate max amplitude (Ampl1./Ampl2.), time of max. detected amplitude (Time1/Time2) in first/second gate, detected amplitude difference, detected time difference
[2]	-	A-Scan control. Double click on a-scan area activates a-scan sub-mode. In this sub-mode operator can move a-scan horizontally, zoom in, zoom out or reset view.
[3]	-	First gate control. Operator can move gate horizontally or vertically, can increase or shorten gate length. Long press on a-scan area forces gate to appear close to the touch point. Operations with the first gate are available only in first gate sub-mode. In order to switch to first gate sub-mode the operator may click on first gate control or activate first gate sub-mode using active touch control.
[4]	-	Second gate control works similar to the first one.
[5]	-	Panel indicates the currently selected gate by triangle. Number in brackets introduces begin and end of the gate expressed in μs.

Table 9: Description of parameters

Parameter	Icon	Description
Farm view	-	See description below.
Averaging	-	Averaging factor can be set to a value from 2 to 16. Software uses averaging factor to compute a-scans from a number of successive following measurements. Averaging can be applied only in A-Scan mode. Set '-' to switch averaging off.
Transmitter	-	Transmitter control allows the operator to select column of transducers in case of linear array mode or single transducer in case of matrix array mode.
Receiver	-	Receiver control allows the operator to select receiver whose waveform will be depicted on a-scan.
Active touch		Option activates a-scan sub-mode. Operator can work with a-scan using touch.
		Option activates first gate sub-mode. Operator can work with the first gate using touch
		Option activates second gate sub-mode. Operator can work with the second gate using touch.
Algorithm		Algorithm for amplitude detection: maximum amplitude withing first gate. Second gate is off.
		Algorithm for amplitude detection: waveform and gate first crossing withing first gate. Second gate is off.
		Algorithm for amplitude detection: maximum amplitude withing first and second gate.
		Algorithm for amplitude detection: waveform and gate first crossing withing first and second gate.
A-scan		Normal waveform visualization
		Rectified waveform representation
		Waveform envelope

Farm View

Enabling of Farm view allows for operator to show all 32 a-scans on a single graph called "Farm view". Such a bird's-eye view may help to diagnose device with respect to broken transducers, electronic failure, high environmental noise etc. Operator can choose between two excitation types: four transducers excites simultaneously and excitation with a single transducer. Select a desired group of

transducers in liner array mode (left image bellow) or a single element transducer in matrix array mode (right image below) by using transmitter control as it shown below

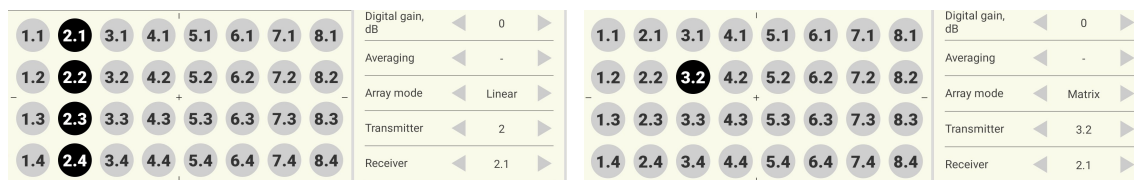

Farm view in linear array mode clearly shows saturation on four transmitting receive whereas in matrix array mode saturation can be observed on the single transmitting receiver.

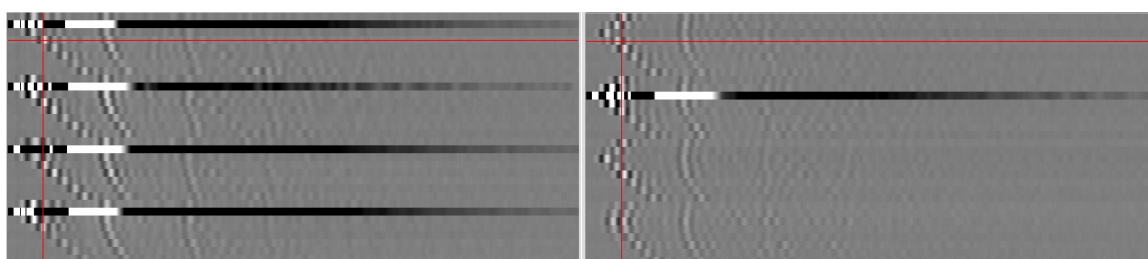

22 Setup

Setup mode allows for the operator to adjust system parameters, scan for online devices, configure instrument, set master and slave instruments, carry out transducer self test.

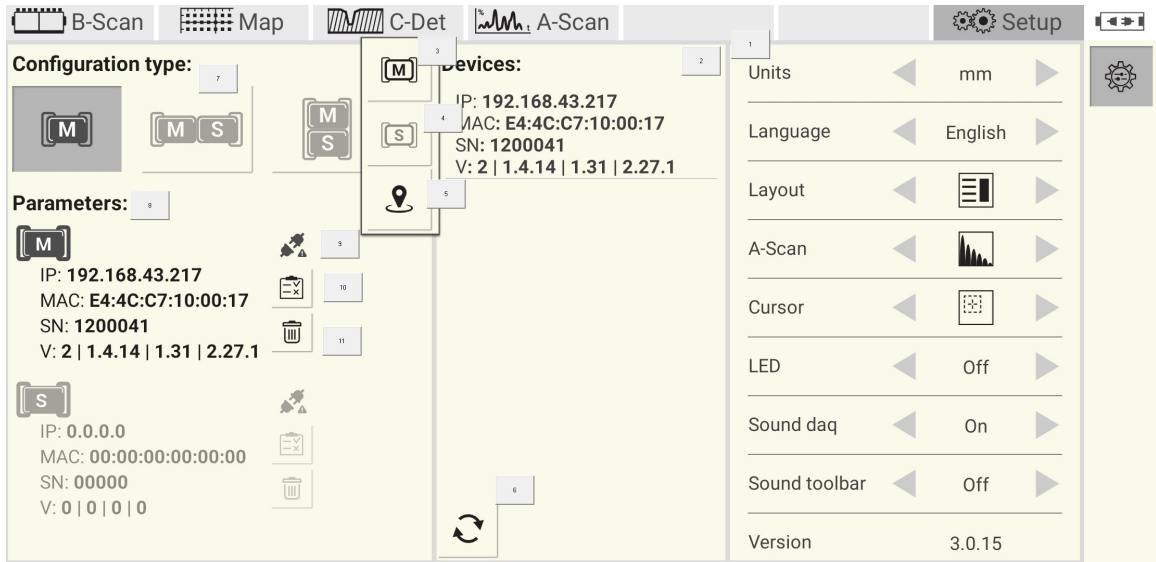

Figure 7: : Description of elements













Label	Icon	Description
[1]	-	Panel lists system parameters. Description of parameters see in table below
[2]	-	Device panel lists online instruments found during scanning process. The App reads and shows system information that includes: IP-adress given by the access point, MAC-Adress, instrument serial number and firmware version number. Double click on a found instrument rises pup up menu with three options described below.
[3]		Sets instrument as master. Current master will be overridden.
[4]		Sets instrument as slave. Current slave will be overridden.
[5]		Button initiates "I'm here" feature. By pressing operator forces selected device to blink by its master LED
[6]		Button calls scanning for online instruments
[7]	-	Instrument configuration section. Operator can specify one of following configurations: 4x8, 4x16 and 8x8. Configurations 4x16 and 8x8 are currently not available.
[8]	-	Sub-panel informs operation about current setting for master and slave instrument. Configuration 4x8 requires only master instrument. Configurations 4x16 and 8x8 require both master and slave instruments.
[9]	-	Indicator shows whether instrument is currently connected.
[10]		Button calls routine for transducer test. Detailed description of transducer test procedure is give here.
[11]		Button removes current instrument

Table 10: Description of parameters

Parameter	Icon	Description
Units	-	Switches to metric or non-metric units
Language	-	User interface language switch
Layout		Parameter selects right hand side location of app control panel
		Parameter defines left hand side location of app control panel
A-Scan		A-Scan is plotted as empty waveform
		A-Scan is plotted as filled waveform
Cursor		Type of cursor offers for the operator automatic search of a maximal amplitude inside cursor area. The position of maximal amplitude is pointed by cross-lines. A-scan waveform corresponds to the horizontal position of the cross-lines.
		Type of cursor offers operator to manually specify position of cross-lines over b-scan. Horizontal and vertical lines are hidden in order to avoid averaging of information shown on b-scan.
		Classical type of cursor with elongated vertical and horizontal cross-lines.
LED	-	Switches device laser pointers LED on/off
Sound daq	-	The app informs operator about finalizing daq by sound signal when switched on.
Sound toolbar	-	If turned on then app conforms parameter changes by sound signal
Version	-	App release version

22.1 Instrument configuration

After the app is being installed or re-installed the operator must configure the instrument. This operation is also required if the operator is planning to change the configuration type between 4x8, 4x16 or 8x8. Instrument configuration is carried out in the steps described below.



Step 1

Switch on the tomograph. It is supposed, that access point parameters are already preset in the tomograph. Wait until "connect" LED starts to blink.

Step 2

Activate a hotspot of the tablet. It is supposed, that access point parameters are already preset in the tablet. Wait until the hotspot establishes a valid connection.

Step 3

Start the app, open setup mode and press button  to scan for online instruments. Scanning process will be indicated with progress bar .

Step 4

All found online devices will be shown in the device list as it is shown below.

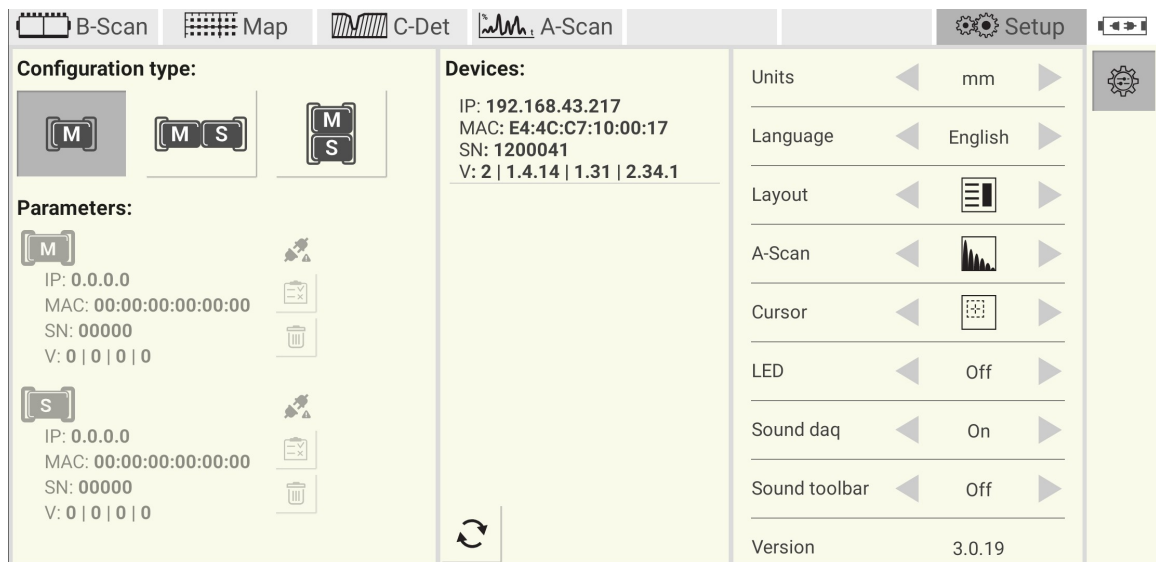

Step 5

Assign the device as a master. The assignment can be carried out by tapping the list of found online devices and pressing  button in the pop up dialog. The parameters of the assigned device are depicted in configuration type panel. The app establishes connection with the assigned device.

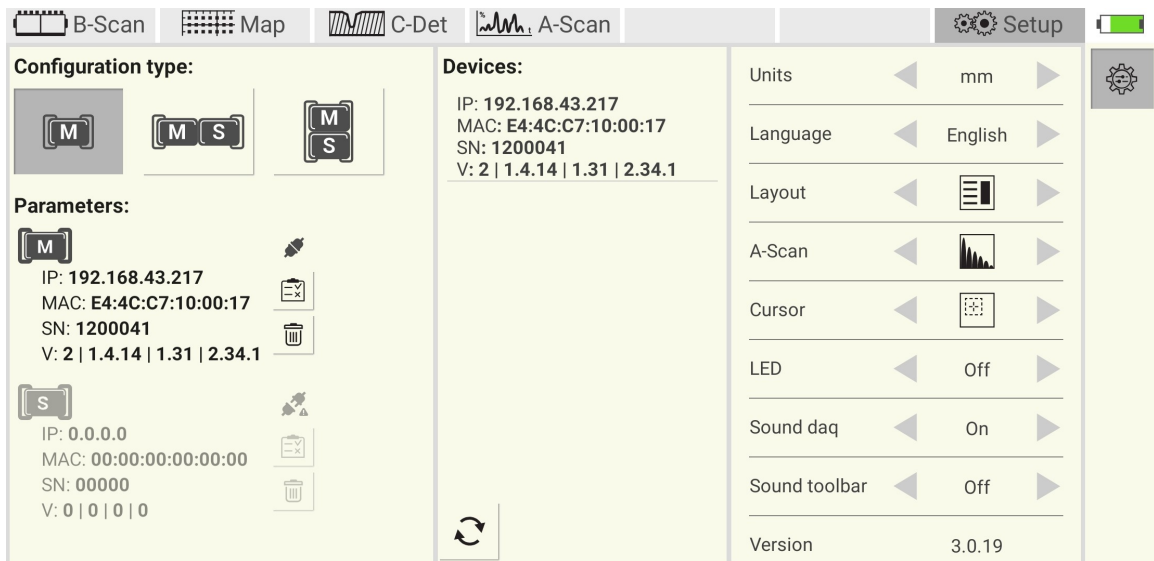

22.2 Automatic transducer testing

The delivery kit includes a test. The sample is a plexiglass plate with a slightly rough surface. It is used to perform the functionality test of each array transducer. For automatic testing and please perform the following steps.

Step 1

Put the sample on a flat, dry and stable surface.

Step 2

Switch on the tomography, start the app on the mobile and ensure that the tomograph goes online. Set the tomograph as master.

Step 3

Start the transducer testing procedure by pressing  button. After pressing it the following window will be shown

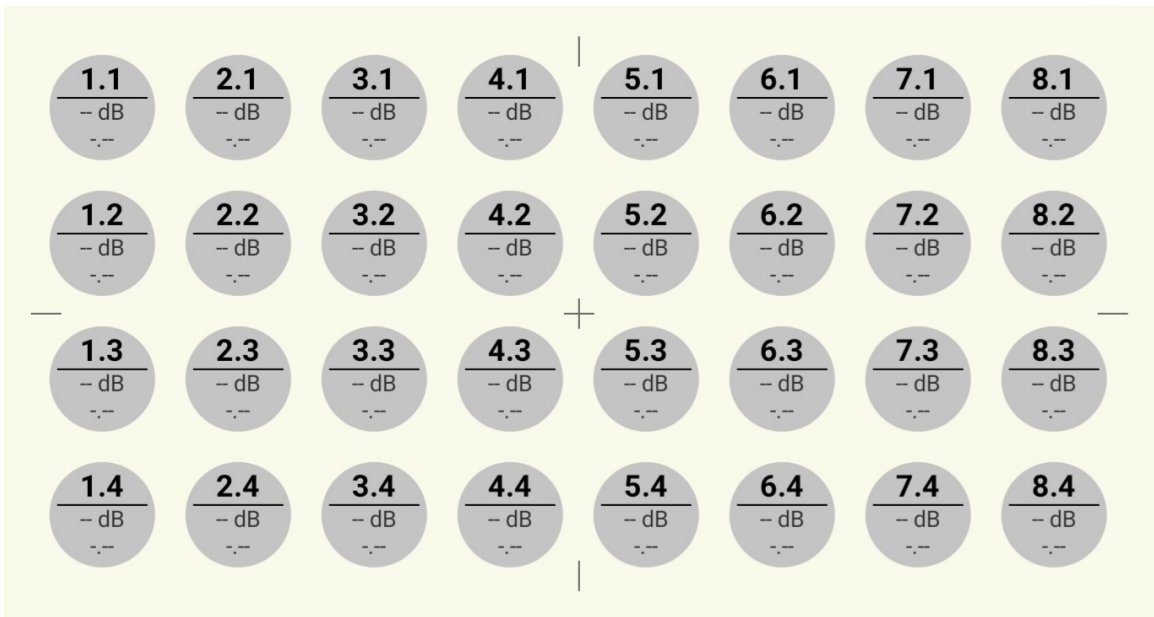

Step 4

Press "data collection" button which is located on the handles of the tomograph. After pressing the button the tomograph starts scanning. The dialog looks as presented below.

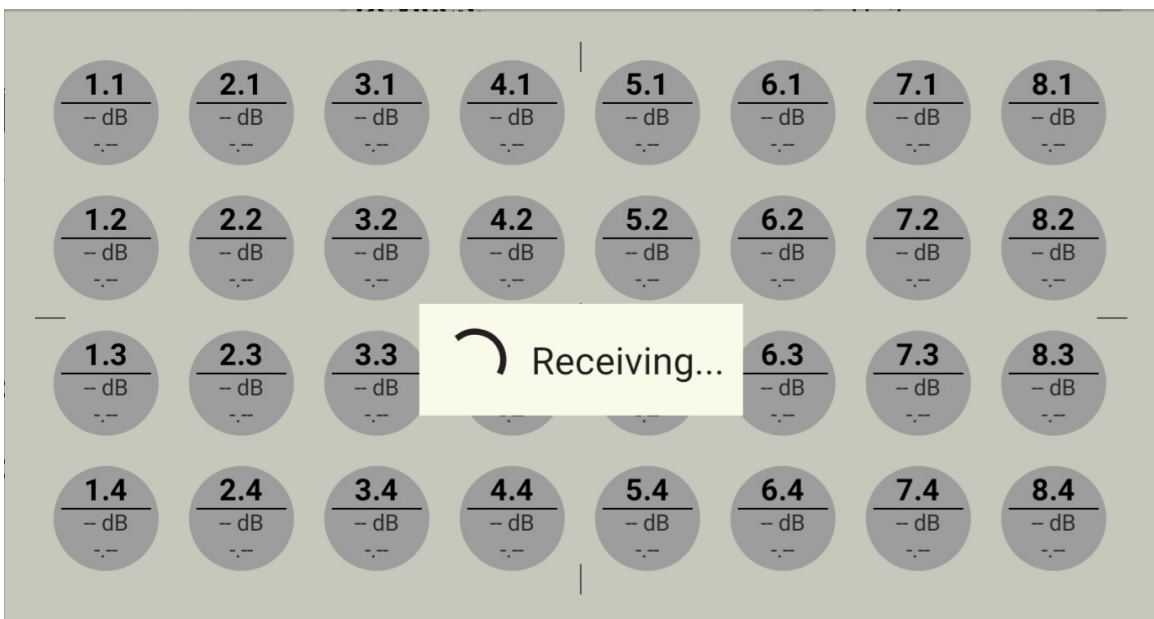

Step 5

In case of a successful test the transducers will be colored green. This means, that tomograph is ready to use.

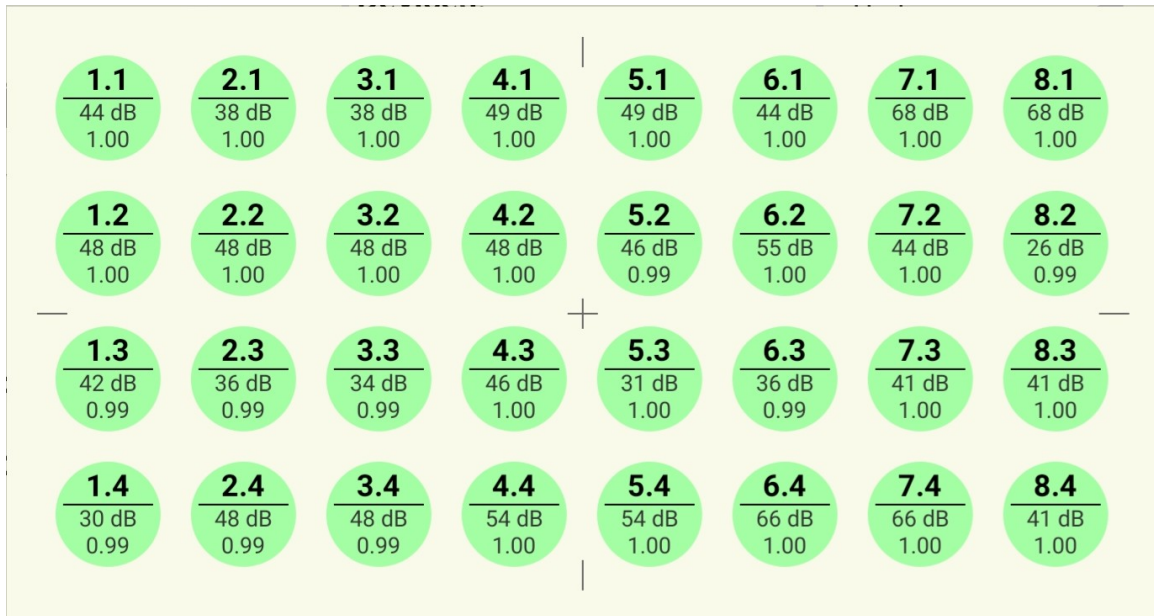

In case of a error a transducer will be colored red.



In this case it is necessary to contact with service center of the manufacturer by e-mail at info@acs-international.com or by phone: +49 681-9659-2270.

23 Getting started

23.1 App installation

This chapter describes the steps for Installation or reinstallation of A1040 MIRA 3D android application

Copying installation package

- Copy installation package com.acs.a1040mira3d-X.X.XX.apk to "acs-solutions apps" tablet internal storage folder. The name of apk file contains X.X.XX symbols. There are placeholders for the package version.

Starting installation and setting permissions

- Start installation and confirm all the requested permissions
- Allow installation permission

Allow Files to install apps?

Downloading apps from external sources will put your device and personal data at greater risk. By touching ALLOW, you indicate that you accept these risks.

Don't ask me again

DENY

ALLOW

- Allow app permissions

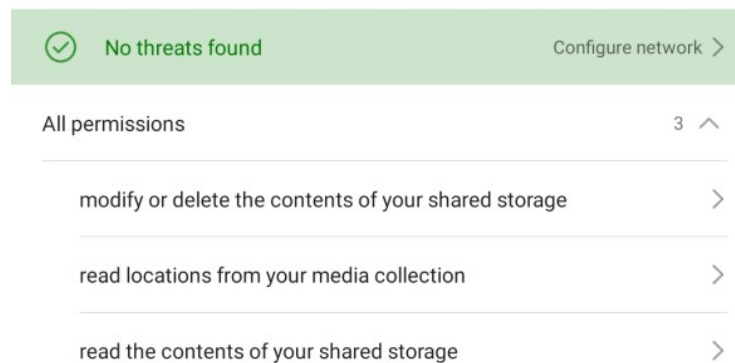

- Allow storage permissions

PERMISSIONS

Storage



23.2 App activation

If the app was installed for the first time, reinstalled or updated it must be activated with a license key. A step-by-step activation procedure is listed below.

Activation procedure

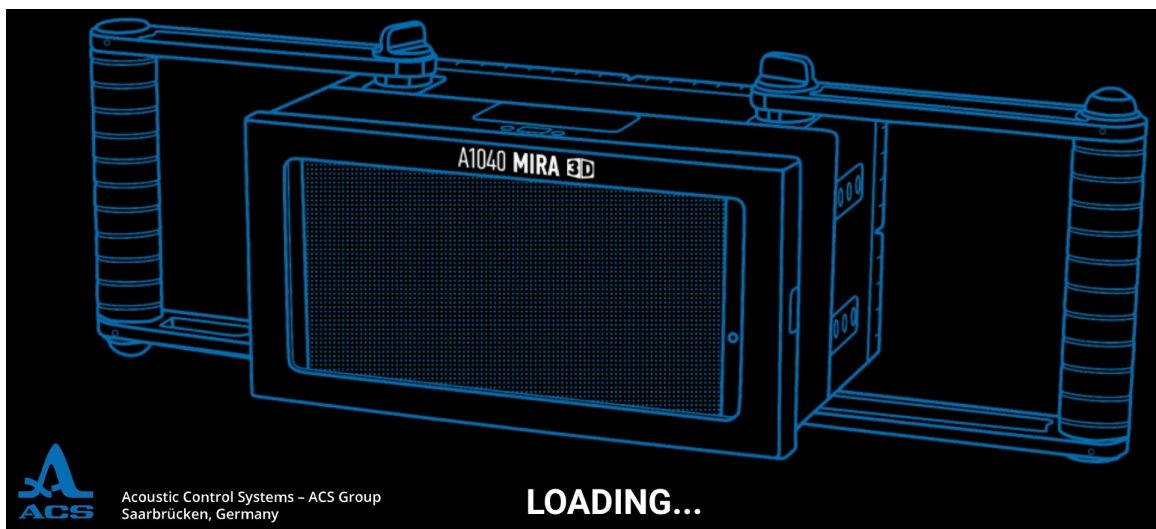

- Establish internet connection before starting the app. For internet access one can use either a SIM-card or WLAN.
- Start the app by tapping on the application icon. The welcome screen presented below appears immediately after start. The app initializes tablet resources as long as the screen is shown. After initialization is finished the activation dialog starts.



- Enter a license key in the activation dialog and press "ICON". The typing errors while entering the license key can be corrected by using keyboard. The app will be trying to verify the license by sending request to the license server. In case of successful verification activation dialog will be closed and notification dialog will be opened.

Enter key and activate your app

1	2	3	4	5	6	7	8	9	0	↩
Q	W	E	R	T	Y	U	I	O	P	Del
A	S	D	F	G	H	J	K	L	Ins	
Z	X	C	V	B	N	M	◀	▶		

- Notification dialog reminds the operator to switch on a personal hotspot. License status  and update status  are also presented in this dialog. The dialog can be closed by single tap.

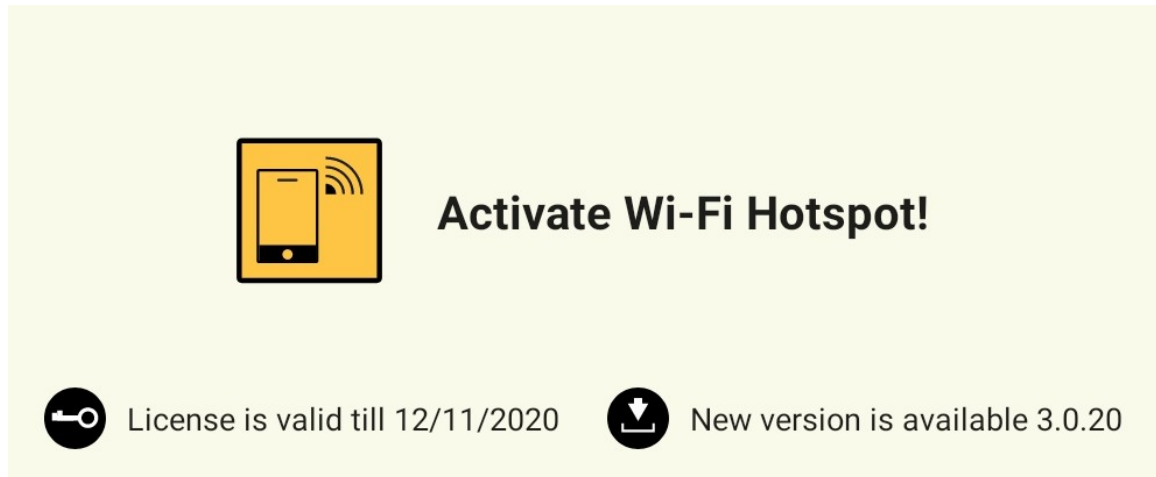

Errors during activation

There is a number of reasons the activation of the app can not be finished: lack of internet connection, license server error, not existing license key or expiration of the license. In case of an error the activation dialog will be extended with one of the following messages:

- Establish internet connection to activate the app
- License server is not available, contact the support
- License expired, contact the support
- License does not exist, contact the support

An example of failed activation is shown below. If you are not able to finish activation press **X** and contact support.

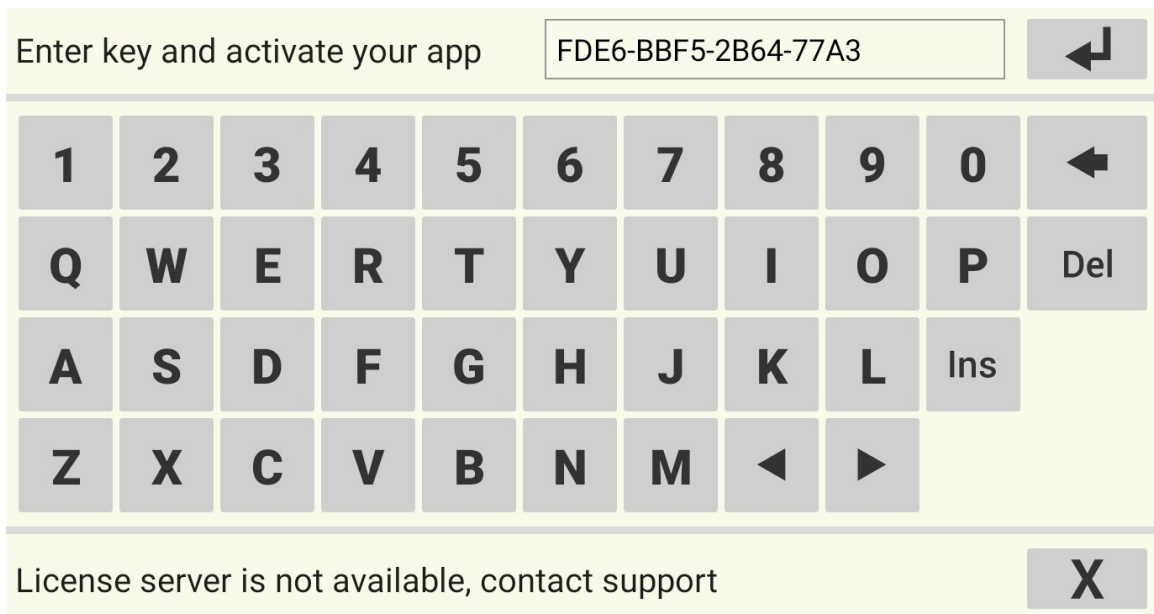

23.3 Preparation for work

In order to start or finish work with the tomograph some preparation steps are required. The description of these steps can be found in this chapter.

Switching on the tomograph

- Press and hold the button power up/down for at least 3 seconds. LED "ON" starts blinking. During that time the operation system of the instrument is being loaded. Finishing of the loading process is indicated by changed state of "ON". The LED lights constantly.

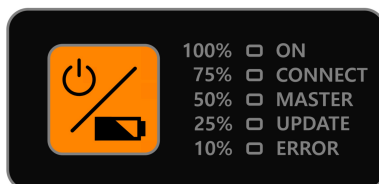

- The tomograph is now ready to establish the connection to hotspot, LED "CONNECT" is blinking.

Starting the app

- Before launching the app you need to switch on the hotspot. It can be done by swiping at the upper part of the table screen to call quick start menu. In the menu activate the hotspot as shown below.

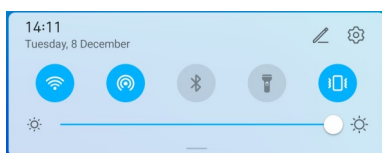

- Successful connection of the tomograph to the hotspot will be indicated by the little number [1] next to the hotspot icon, see the following image.



- Launch the app and create a new configuration as it is described in [Setup](#) ⁵⁵ chapter. Finalize the configuration and connect to the instrument. If the configuration has already been created, the app will try to establish connection with the tomograph automatically. If the connection was successfully established, LED "CONNECT" starts glowing constantly. The tomograph is ready to work.

Closing the app

The operator can close the A14040 MIRA 3D app using standard approach.

Switch off the tomograph

- The tomograph can be switched off by pressing and holding the power button for 3 seconds. The switching off procedure discharges all capacitors inside of the tomograph in order to get rid of residual voltage. While discharging all the LEDs are simultaneously blinking.
- In rare case the tomograph is hanging in such a way that operation system does not respond. In this case, press and hold the power button for 10 seconds.

23.4 Update

The system update includes both renewals of the micro-controller firmware and the app. There are two ways to update the app: the *Automatic* or *Manual* update. During the *Automatic* update the app updates itself if an internet connection and the license server are available. If the internet connection or license server is not available the app can be updated manually.

Automatic update

- The notification dialog informs the operator about a new available app version on the license server.

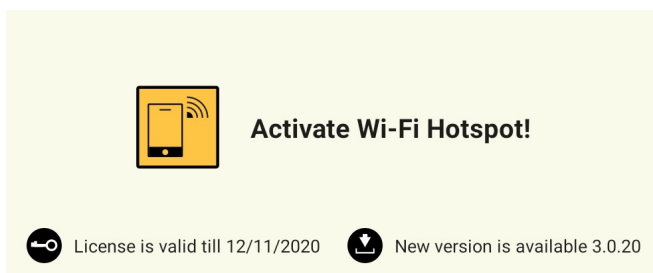

- Force the update by pressing the  button in *setup* mode:

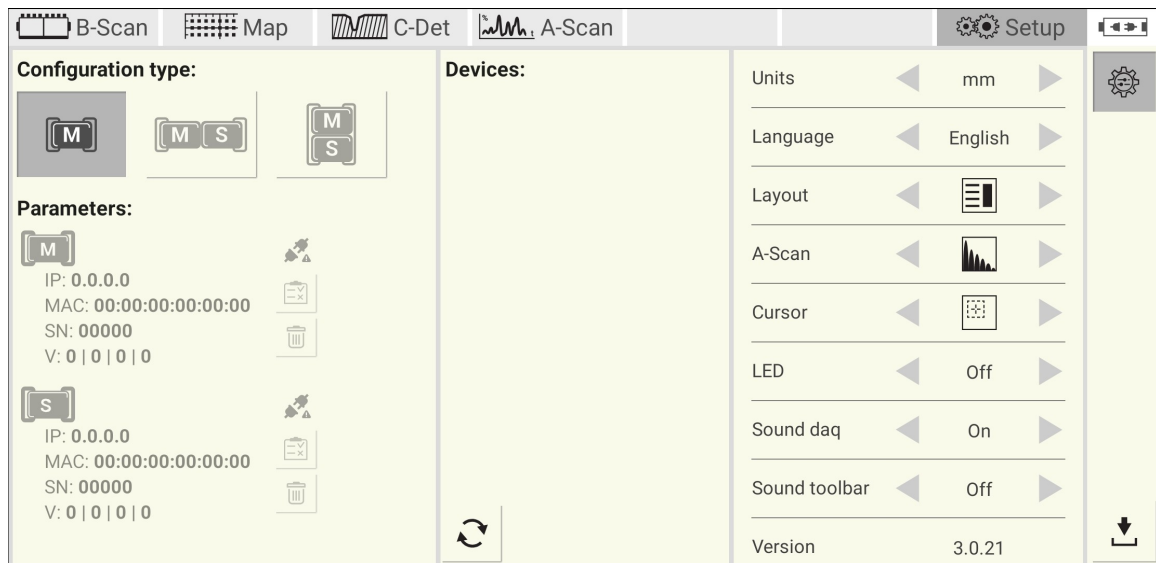

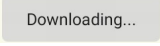
- Wait until the app will be downloaded from the server. The downloading process is accompanied by the progress dialog 
- After downloading is completed wait until the installation process is started. The installation of the update is similar to the app installation described in the chapter Getting started at [page 63](#). The new app version will be activated automatically by taking the license key from the previous installation.

Manual update

The manual update to be done in as follows:

- Download the installation package from A1040 MIRA 3D homepage
- Follow up steps described at [page 63](#) including app installation and activation.

Firmware update

The A1040 MIRA 3D app informs the operator about the necessity of the firmware update. The update to be performed as follows:

- Switch off the A1440 MIRA 3D
- Download the latest firmware from A1040 MIRA 3D home page
- Connect the USB cable to the Windows PC TYPE A plug
- Press and hold the power button (). Within the next 2 seconds, connect the USB cable to the instrument TYPE C plug. The update indicator is on now. It confirms the device's readiness for the update.
- Windows PC detects the A1040 MIRA 3D storage device. Please, open it in the file explorer.

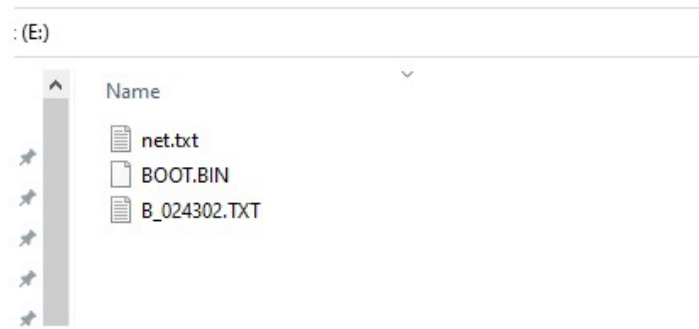

- Delete following files: `BOOT.BIN` and `B_?????.TXT`
- Copy the new firmware file to the storage. The `update` indicator is blinking while the firmware file is being copied. Wait until the `update` indicator stops blinking.
- Disconnect the `A1040 MIRA 3D` from the PC. The instrument is updated now.
- Start the instrument, connect the device to the app, and finally, check the firmware version in the setup mode.